

Variable Displacement Axial Piston Pump

TH-A10VSO

Series 31



TECH HYDRO Variable Piston Pump TH-A10VSO series 31 - Rev. C (08/31/2023)





TECH HYDRO

Power. Precision. Performance.

TABLE OF CONTENTS

DESCRIPTION	4	DIMENSIONS, SIZE 45, SERIES 31	19-20
Features	4	TH-A10V(S)O-45.....	19
Technical Specifications.....	4	Drive Shafts TH-A10V(S)O-45.....	20
		Ports TH-A10V(S)O-45.....	20
FEATURES/CROSS-SECTION	5	DIMENSIONS, SIZE 71, SERIES 31	20-21
TECHNICAL DATA	6	TH-A10V(S)O-71	20
ORDERING INSTRUCTIONS	7	Drive Shafts TH-A10V(S)O-71	21
DR - PRESSURE CONTROLLER	8	Ports TH-A10V(S)O-71	21
DR Controller Data	8	DIMENSIONS, SIZE 100, SERIES 31	22-23
DRG - PRESSURE CONTROLLER, REMOTE CONTROLLED	9	TH-A10V(S)O-100	22
DRG Controller Data.....	9	Drive Shafts TH-A10V(S)O-100	23
DFR/DFR1 - PRESSURE AND FLOW CONTROLLER	10	Ports TH-A10V(S)O-100.....	23
DFR/DFR1 Flow Control/Differential Pressure.....	10	DIMENSIONS, SIZE 140, SERIES 31	24
DFR/DFR1 Controller Data.....	10	TH-A10V(S)O-140	24
DFLR - PRESSURE, FLOW AND POWER CONTROLLER	11	Drive Shafts TH-A10V(S)O-140	24
DFLR Controller Data.....	11	Ports TH-A10V(S)O-140.....	24
DIMENSIONS DR	12	THROUGH DRIVE MOUNTING OPTIONS, SHAFT TORQUE DATA	25-26
DIMENSIONS DRG/DFR/DFR1	13	DIMENSIONS OF THROUGH DRIVES	26-28
DIMENSIONS DFLR	14	K01 Flange.....	26
DIMENSIONS, SIZE 18, SERIES 31	15	K52 Flange, K68 Flange, K04 Flange.....	27
TH-A10V(S)O-18.....	15	K07 Flange, K24 Flange, K17 Flange.....	28
Drive Shafts TH-A10V(S)O-18	15	PERFORMANCE DATA - POWER DRIVE AND FLOW	29-31
Ports TH-A10V(S)O-18.....	15	Size 18, Size 28, Size 45	29
DIMENSIONS, SIZE 28, SERIES 31	16-17	Size 71, Size 100.....	30
THA10V(S)O-28.....	16	Size 140.....	31
Drive Shafts TH-A10V(S)O-28.....	17	NOISE LEVEL	32
Ports TH-A10V(S)O-28.....	17	PUMP INSTALLATION NOTES	33
		NOTES	34-35

TH-A10VSO Series 31

Variable Displacement Axial Piston Pump



DESCRIPTION

TH-A10V(S) series variable displacement axial piston pumps are designed for open loop circuits and can be used in both mobile and industrial applications. The output flow is proportional to the drive speed and the displacement.

The TH-A10V(S) series pumps are available in six displacements, ranging from 1.10 in³/rev (18 cm³/rev) to 8.54 in³/rev (140 cm³/rev). They offer speeds up to 3,300 rpm, a rated working pressure of 4000 psi (280 bar), single pump or through drive pumps allowing for multi-circuit systems. Offered in SAE or Metric mounting with side or rear porting.

Available in a variety of controls with short control response times. These variable pumps offer the benefit of providing power only when needed.



FEATURES

- Variable pump with axial piston rotary group in swashplate design
- Series 31 in sizes 18, 28, 45, 71, 100, 140
- Designed for open loop circuits
- Output flow is proportional to the drive speed and displacement and can be infinitely varied by adjusting the swashplate angle.
- Versatile controller range
- Short control time
- Excellent suction performance
- Low noise nine-piston design
- Long service life
- Favorable power/weight ratio
- Offered with Buna-N or Viton seal options
- End or side inlet and outlet ports for design flexibility
- Multiple case drain ports for various mounting orientations
- Full power through drive capability

TECHNICAL SPECIFICATIONS

Model	Displacement $V_{g_{max}}$		Max. Speed n_{max} rpm	Max. Flow $Q_{v_{max}}$		Pressure PSI		Max. Power		Suction Port S →	Pressure Port B →	Drain Port L, L1 ↓	Pilot Port X ○○○○	Weight (approx.)	
	cm ³ /r	in ³ /r		gpm	lpm	Rated	Max	hp	kW					lbs	kg
TH-A10V(S)-O-18	18	1.10	3300	15.7	59.4	4000	5000	38	28	1" CD 61 (3/8-16 UNC-2B)	3/4" CD 61 (3/8-16 UNC-2B)	SAE-6	SAE-4	28.7	13
TH-A10V(S)-O-28	28	1.71	3000	22.2	84	4000	5000	52	39	1-1/4" CD 61 (7/16-14 UNC-2B)	3/4" CD 61 (3/8-16 UNC-2B)	SAE-8	SAE-4	37.5	17
TH-A10V(S)-O-45	45	2.75	2600	30.9	117	4000	5000	74	55	1-1/2" CD 61 (1/2-13 UNC-2B)	1" CD 61 (3/8-16 UNC-2B)	SAE-10	SAE-4	50.7	23
TH-A10V(S)-O-71	71	4.33	2200	41.2	156	4000	5000	98	73	2" CD 61 (1/2-13 UNC-2B)	1" CD 61 (3/8-16 UNC-2B)	SAE-10	SAE-4	79.4	36
TH-A10V(S)-O-100	100	6.10	2000	52.8	200	4000	5000	125	93	2-1/2" CD 61 (1/2-13 UNC-2B)	1-1/4" CD 62 (1/2-13 UNC-2B)	SAE-12	SAE-4	110.2	50
TH-A10V(S)-O-140	140	8.54	1800	66.5	251	4000	5000	158	118	2-1/2" CD 61 (1/2-13 UNC-2B)	1-1/4" CD 62 (1/2-13 UNC-2B)	SAE-12	SAE-6	143.3	65

Notes:

1. **Absolute pressure at suction port S (inlet):** Ps min: 11.6 psi (0.8 bar), Ps max: 435 psi (30 bar)
2. **Viscosity:** optimal range 16 to 36 mm²/s (80 to 170 SUS)
3. **Temperature:** T min = -20°C (-4°F), T max = +80°C (+176°F)
4. **Filtration of the hydraulic fluid:** A cleanliness level of at least 20/18/15 is to be maintained according to ISO 4406. At very high hydraulic fluid temperatures (maximum 230 °F (110 °C), measured at Drain port L, L1), at least a cleanliness level of 19/17/14 according to ISO 4406 is necessary.
5. **Cold start:** Allow pump to run ≤ 3 minutes without load (p ≤ 725 psi (50 bar)), Speed ≤ 1000 rev/min. Permissible temperature difference between axial piston unit and hydraulic fluid in the system maximum 45 °F (7.2°C).
6. **Weight:** indicated in the table correspond to units without through drive and are approximate.

FEATURES

TECHHYDRO TH-A10V series variable piston pump with axial piston rotary group in swashplate design for hydrostatic drives in open circuit. Flow is proportional to drive speed and displacement and by adjusting the position of the swashplate it is possible to smoothly vary the flow.

- Flange connections to SAE (UNC) or ISO (metric)
- Two case drain ports
- Excellent suction characteristics
- High permissible speeds
- Axial and radial loading of drive shaft possible
- Wide range of controllers with short control response time

DR – Pressure controller

DRG – Pressure controller, remotely controlled

DFR/DFR1 – Pressure flow controller

DFLR – Pressure, flow and power controller

- Low noise nine-piston design

- Long service life
- Good power to weight ratio
- Through drive option for multi-circuit systems, allows adding gear and axial piston pumps up to the same size (100% through drive)
- “Mechanical Displacement Limiter” on all non-through drive models with 12N00 and 62N00 end covers allow for physical limitation of pump's maximum rated displacement ($V_{g_{max}}$). (Caution, If the pump flow is reduced more than 30% of max. displacement using this physical limiter, it will negatively affect service life of the pump)

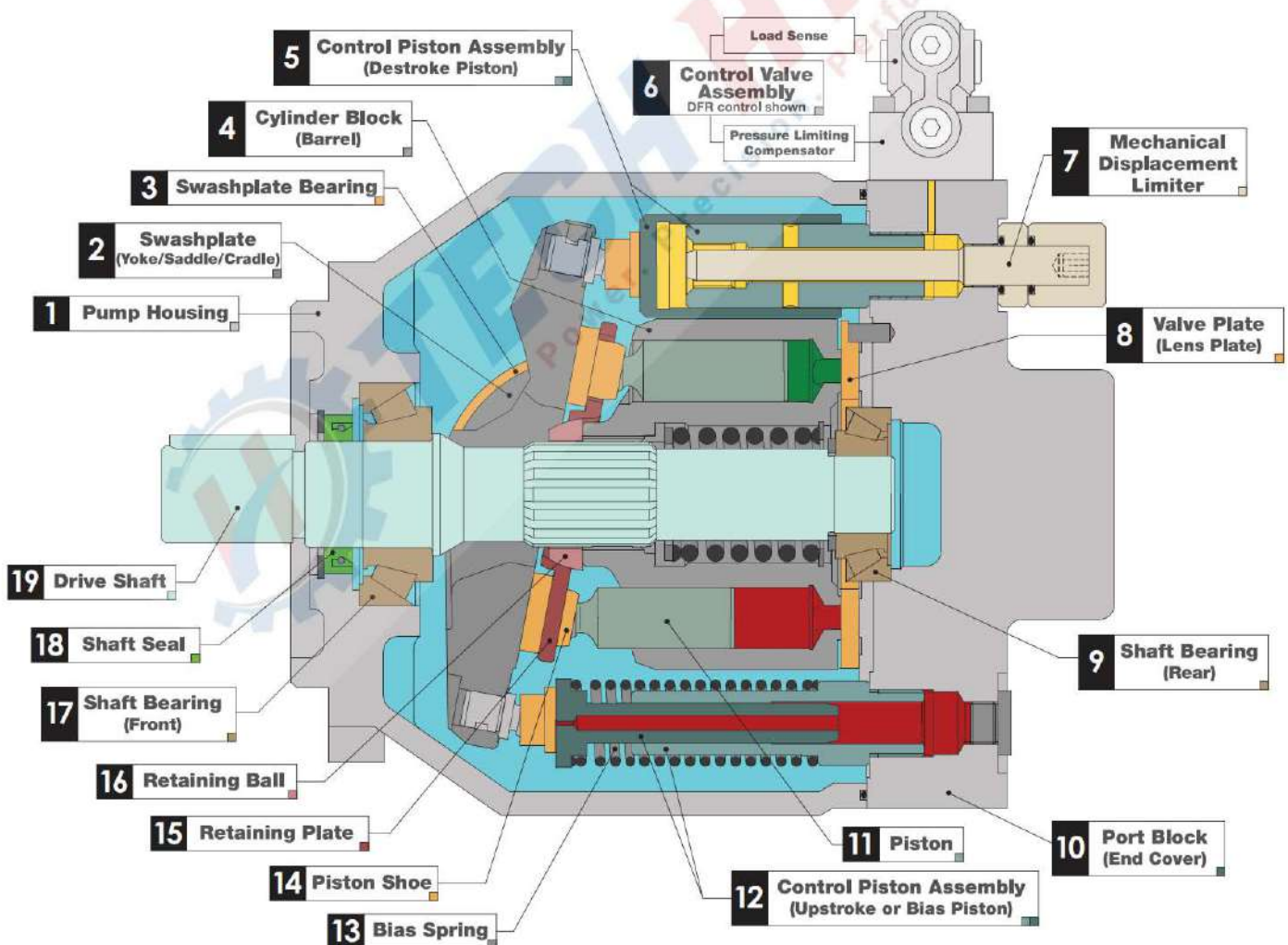

TECHNICAL DATA

Input operating pressure range

Absolute Pressure at inlet Port S	
$P_{abs \text{ min}}$	11.6 psi (0.8 bar)
$P_{abs \text{ max}}$	435 psi (30 bar)

Output operating pressure range

Pressure at Port B	
Nominal pressure p_N	4000 psi (280 bar)
Peak Pressure p_{max}	5000 psi (350 bar)

Case drain pressure

Maximum pressure of leakage fluid (at ports L, L1 is 7 psi (0.5 bar) higher than input pressure at port S, but not higher than 30 psi (2 bar) absolute.

Direction of flow

“S” inlet port to “B” pressure port

Table of values (theoretical values, without considering η_{hm} and η_v ; values rounded)

Size			18	28	45	71	100	140
Displacement	$V_{g \text{ max}}$	in ³ /rev (cm ³ /rev)	1.10 (18)	1.71 (28)	2.75 (45)	4.33 (71)	6.10 (100)	8.54 (140)
Max. Speed	n_{max}	rpm	3300	3000	2600	2200	2000	1800
Max. Flow	$q_{v \text{ max}}$	gpm (lpm)	15.7 (59.4)	22.2 (84)	30.9 (117)	41.2 (156)	52.8 (200)	66.5 (251)
Max. Power $\Delta p = 4000 \text{ psi (280 bar)}$	P_{omax}	hp (kW)	38 (28)	52 (39)	74 (55)	98 (73)	125 (93)	158 (118)
Max. Torque $\Delta p = 4000 \text{ psi (280 bar)}$	T_{omax}	ft-lb (Nm)	59 (80)	92 (125)	148 (200)	233 (316)	328 (445)	460 (623)
Weight w/o through drive (approx.)		lbs (kg)	28.7 (13)	39.7 (18)	52.9 (24)	79.4 (36)	110.2 (50)	144.4 (65.5)
Weight with through drive (approx.)		lbs (kg)	32 (14.5)	44.8 (20.3)	57.3 (26)	85 (38.6)	123.5 (56)	165.3 (75)

Notes:

- Values shown are valid for an absolute pressure of 1 bar at suction port. If the flow is reduced or if the inlet pressure is increased, the speed may be increased.
- “Mechanical Displacement Limiter” comes standard on all pumps sizes 18/28/45/71/100/140 with the 12N00 and 62N00 end cover.

Determining the operating characteristics

	IMPERIAL ^U		METRIC ^M	
Flow	q_v	$q_v = \frac{V_g \cdot n \cdot \eta_v}{231}$ gpm	q_v	$q_v = \frac{V_g \cdot n \cdot \eta_v}{1000}$ lpm
Torque	T	$T = \frac{V_g \cdot \Delta p}{24 \cdot \pi \cdot \eta_{hm}}$ lb-ft	T	$T = \frac{V_g \cdot \Delta p}{20 \cdot \pi \cdot \eta_{hm}}$ Nm
Power	P	$P = \frac{q_v \cdot \Delta p}{1714 \cdot \eta_t}$ hp	P	$P = \frac{q_v \cdot \Delta p}{600 \cdot \eta_t}$ kW

Key

V_g	Displacement per revolution in in ³ (cm ³)
Δp	Differential pressure in psi (bar)
n	Speed in rpm
η_v	Volumetric efficiency
η_{hm}	Hydraulic-mechanical efficiency
η_t	Total efficiency ($\eta_t = \eta_v \cdot \eta_{hm}$)

Notes:

- Theoretical values, without efficiency and tolerances; values rounded
- Operation above the maximum values or below the minimum values may result in a loss of function, a reduced service life or in the destruction of the axial piston unit. TECH HYDRO recommends checking the load by means of test or calculation / simulation and comparison with the permissible values.

DESIGNATION & ORDERING CODE

TH-A10V(S) - O - 100 - DFR1 - 31 - R - P - K - C - 62 - N00

1	2	3	4	5	6	7	8	9	10	11
---	---	---	---	---	---	---	---	---	----	----

1 Axial Piston Unit

TH-A10V	Swashplate Design, Variable Pump
TH-A10VS	Swashplate Design, Variable Pump (Industrial)

2 Operating Mode

O	Pump, Open Circuit
---	--------------------

3 Displacement

	cm ³ /rev	in ³ /rev		cm ³ /rev	in ³ /rev
18	18	1.10	71	71	4.33
28	28	1.71	100	100	6.10
45	45	2.75	140	140	8.54

4 Control Device

		18	28	45	71	100	140
DR	Pressure Control	•	•	•	•	•	•
DRG	Pressure Remote Control	•	•	•	•	•	•
DFR	Pressure & Flow Control (X-T open)	•	•	•	•	•	•
DFR1	Pressure & Flow Control (X-T plugged)	•	•	•	•	•	•
DFLR	Pressure, Flow & Power Control	-	•	•	•	•	•

5 Series

31	Series
----	--------

6 Direction of Rotation

R	Clockwise	L	Counter-clockwise
---	-----------	---	-------------------

7 Seal Material

P	Buna-N	V	FKM Fluorocarbon Viton®
---	--------	---	-------------------------

8 Drive Shaft

		18	28	45	71	100	140
K	SAE Parallel Keyed Shaft	3/4" 7/8" 1" 1 1/4" 1 1/2" 1 3/4"	Key width 3/16" 1/4" 1/4" 5/16" 3/8" 7/16"				
S	SAE Splined Shaft	3/4" 7/8" 1" 1 1/4" 1 1/2" 1 3/4"	Number of Teeth 11 13 15 14 17 13				
R	SAE Splined Shaft, Reinforced (Similar to shaft S however for higher input torque)	- - 1" 1 1/4"*	-	-	-	-	
		Number of Teeth - - 15 14 - -					
U	SAE Splined Shaft, Smaller size (Reduced diameter, not for through drive)	5/8" - 7/8" 1" 1 1/4"	-	-	-	-	
		Number of Teeth 9 - 13 15 14 -					
P	Metric Parallel Keyed Shaft (DIN 6885)	18 22 25 32 40 45	Key width (mm) 6 6 8 10 12 14				

* Non-Thru Drive Models Only

† Thru Drive Models Only

U Imperial M Metric

9 Mounting Flange

		18	28	45	71	100	140
C	SAE 2-Bolt	3 1/4" SAE A	4" SAE B	4" SAE B	5" SAE C	5" SAE C	-
A	ISO 2-Bolt	(mm) 80	100	100	125	125	-
D	SAE 4-Bolt	-	-	-	-	-	6" SAE D
B	ISO 4-Bolt	(mm) -	-	-	-	-	180

10 Service Ports

		18	28	45	71	100	140
Pressure Port B & Suction Port S							
61	Rear Ports, UNC Mounting Screws ^{1,2}	-	•	•	•	•	•
62	Opposite Side Ports, UNC Mounting Screws ²	•	•	•	•	•	•
11	Rear Ports, Metric Mounting Screws ¹	-	•	•	•	•	•
12	Opposite Side Ports, Metric Mounting Screws	•	•	•	•	•	•
41	Rear Ports, UNC Mounting Screws ^{1,2}	•	•	•	•	•	•
91	Rear Ports, UNC Mounting Screws ²	•	•	•	•	•	•
42	Opposite Side Ports, Metric Mounting Screws ¹	•	•	•	•	•	•
64	Rear Ports, Metric Mounting Screws	•	•	•	•	•	•
92	Opposite Side Ports, Metric Mounting Screws ¹	•	•	•	•	•	•
14	Rear Ports, Metric Mounting Screws	•	•	•	•	•	•

Port pos. 61, 11 only for version without Through drive

¹ All rear porting, non-Through drive only

² TH-A10V071 = 8 threaded holes on pressure port code 11, 61, 12 & 62

11 Through Drive

		18	28	45	71	100	140
N00	Without Through Drive	•	•	•	•	•	•

With through drive to accept axial piston or gear pump

	Mounting Fig.	Coupling for	18	28	45	71	100	140
K01	82-2 (SAE A)	5/8" 9T 16/32DP (SAE A)	•	•	•	•	•	•
K52	82-2 (SAE A)	3/4" 11T 16/32DP (SAE A-B)	•	•	•	•	•	•
K68	101-2 (SAE B)	7/8" 13T 16/32DP (SAE B)	-	•	•	•	•	•
K04	101-2 (SAE B)	1" 15T 16/32DP (SAE B-B)	-	•	•	•	•	•
K07	127-2 (SAE C)	1 1/4" 14T 12/24DP (SAE C)	-	-	-	•	•	•
K24	127-2 (SAE C)	1 1/2" 17T 12/24DP (SAE C-C)	-	-	-	-	•	•
K17	152-4 (SAE D)	1 3/4" 13T 8/16DP (SAE D)	-	-	-	-	-	•

*Contact TECH HYDRO if Through Drive option required is not listed.
 TECH HYDRO Variable Piston Pump TH-A10VSO series 31 - Rev. C (08/31/2023)

DR - PRESSURE CONTROLLER

The DR pressure controller maintains the maximum pressure at the pump outlet within the control range of the pump. The pump will therefore only supply as much hydraulic fluid as is required by the actuators. If the working pressure exceeds the pressure setting at the pressure valve, the pump will regulate to a smaller displacement to reduce the control differential.

- **Basic position in depressurized state:**
Vg max. (Max. displacement)
- **Setting range for pressure control:**
50 to 280 bar. Standard is 280 bar.

1. Pressure controller - DR

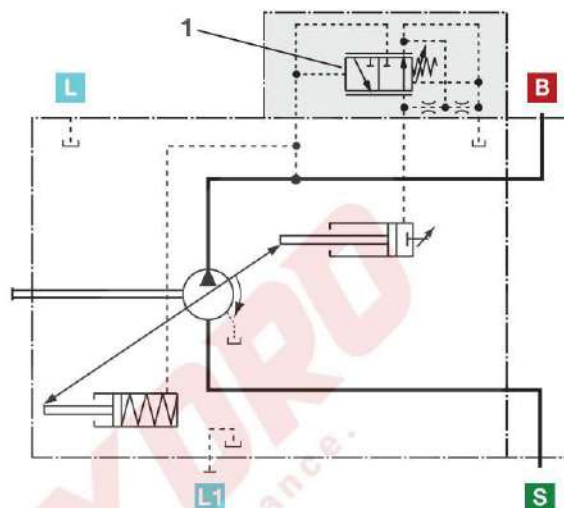

Ports

- B** Pressure port
- S** Suction port
- L, L1** Case drain ports (L1 plugged)

Static characteristic
at $n = 1450 \text{ rpm}$; $t_{fluid} = 50^\circ\text{C} (122^\circ\text{F})$

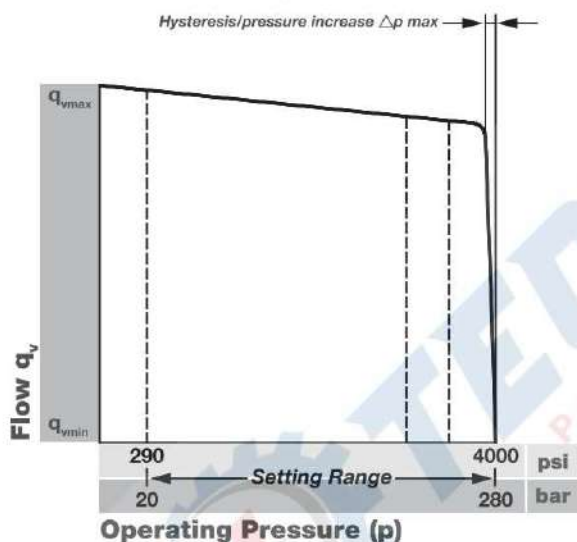

DR Controller Data

Size	18	28	45	71	100	140
Δp psi (bar)	58 (4)	58 (4)	87 (6)	116 (8)	145 (10)	174 (12)
Hysteresis and repeatability accuracy Δp	Max. 45 psi (3 bar)					
Pilot oil consumption	0.8 gpm (3 lpm)					

DRG - PRESSURE CONTROLLER, REMOTE CONTROLLED

For the DRG remote controlled pressure controller, the load sense LS pressure limitation is performed using a separately arranged pressure relief valve*. Therefore any pressure control value under the pressure set on the pressure controller can be regulated.

*The separate pressure relief valve and the line are not included in the scope of delivery.

The standard setting on the remote controlled pressure cut-off of LS is 290 psi (20 bar), the amount of control fluid at port is X approx. 0.4 gpm (1.5 l/min). If a different setting (range 145 to 320 psi (10 to 22 bar)) is required, please state in plain text.

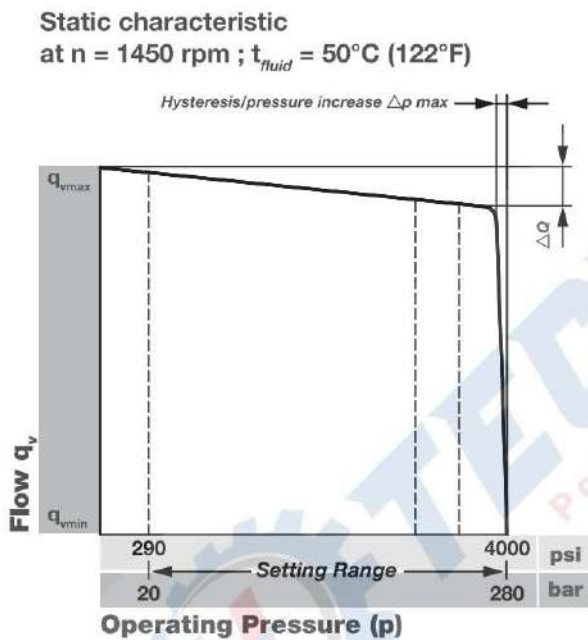

1. The separate pressure relief valve and the line are customer supplied
2. Remote controlled pressure cut-off (G)
3. Pressure controller (DR)

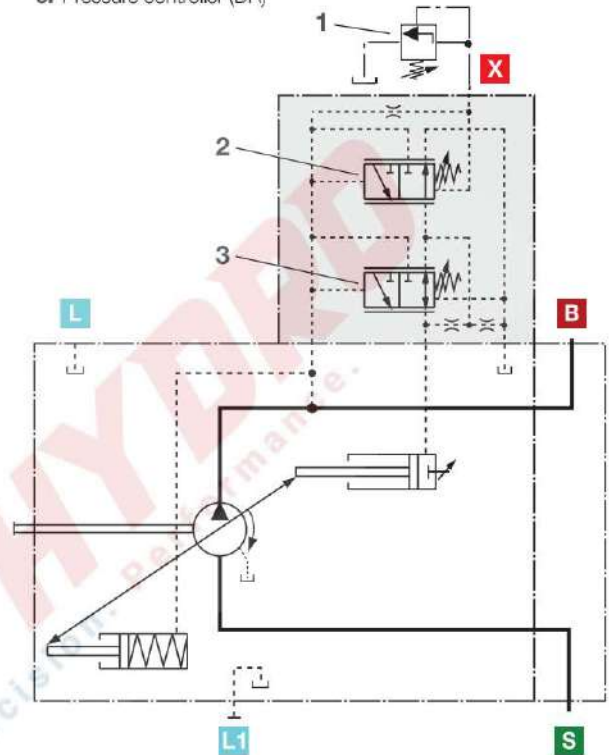

Ports

B	Pressure port
S	Suction port
L, L1	Case drain ports (L1 plugged)
X	Pilot pressure port

DRG Controller Data

Size	18	28	45	71	100	140
Δp psi (bar)	58 (4)	58 (4)	87 (6)	116 (8)	145 (10)	174 (12)
Hysteresis and repeatability accuracy Δp	Max. 45 psi (3 bar)					
Pilot oil consumption	1.19 gpm (4.5 lpm)					

DFR/DFR1 - PRESSURE AND FLOW CONTROLLER

In addition to the pressure control function, the pump flow may be varied by means of a differential pressure at the actuator (e.g. an orifice).

In DFR1 model the bleed down orifice is plugged.

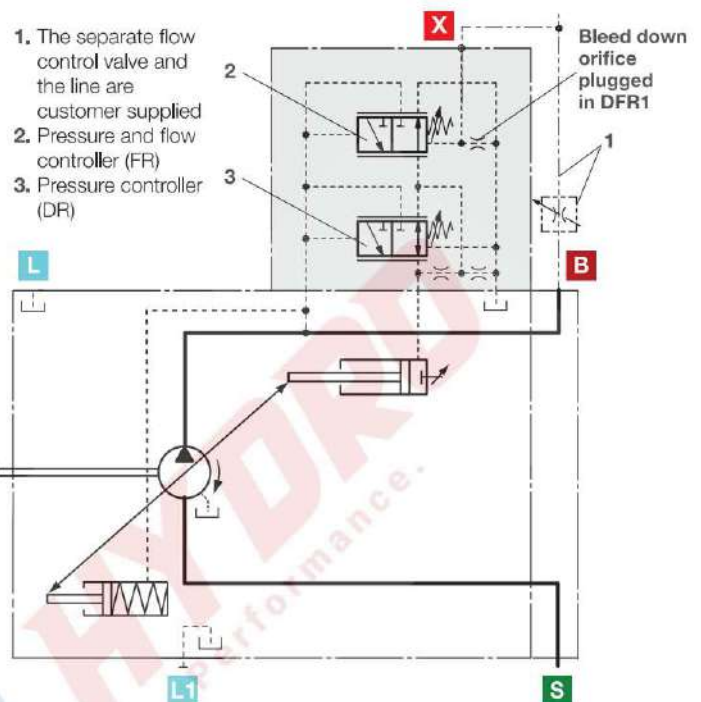

Ports	
B	
S	
L, L1	
X	

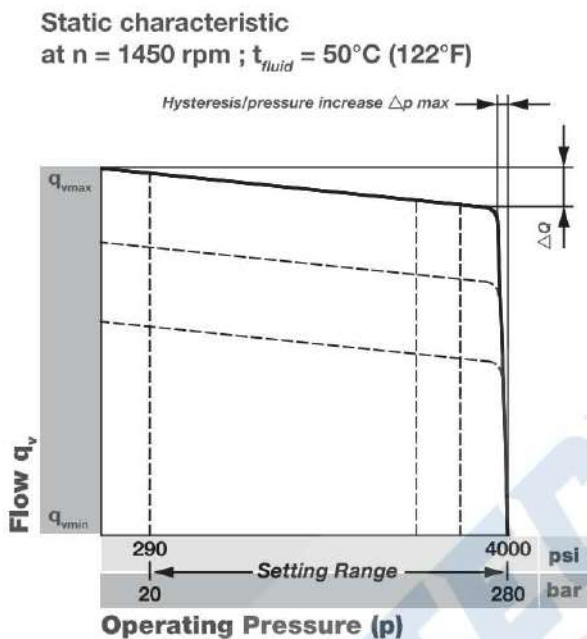

FLOW CONTROL/DIFFERENTIAL PRESSURE Δp

Standard setting: 14 bar (203psi). If a different setting is required, please state in clear text.

When port X is unloaded to tank, a zero stroke pressure ("stand by") of $p = 260 \pm 30 \text{ psi} (18 \pm 2 \text{ bar})$ results.

Static characteristic at variable speed

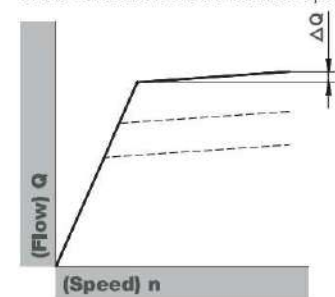

DFR/DFR1 Controller Data

■ For pressure control technical data see DR Pressure Control.

Size	18	28	45	71	100	140
ΔQ_{max} lpm (gpm)	0.9 (0.24)	1.0 (0.26)	1.8 (0.48)	2.8 (0.74)	4.0 (1.06)	6.0 (1.6)
Hysteresis & repeatability Δp bar (psi)	Max. 60 psi (4 bar)					
Pilot oil consumption	DFR: Max. approx. 0.70-1.19 gpm (3-4, 5 lpm) DFR1: Max approx. 0.70 gpm (3 lpm)					

DFLR - PRESSURE, FLOW AND POWER CONTROLLER

In order to achieve a constant drive torque with a varying operating pressure, the swivel angle and with it the output flow from the axial piston unit is varied so that the product of flow and pressure remain constant.

Flow control is possible below the limit of the power curve.

Execution of the pressure control like DR(G), see page 6.
Execution of the flow control like DFR, DFR1, see page 8.

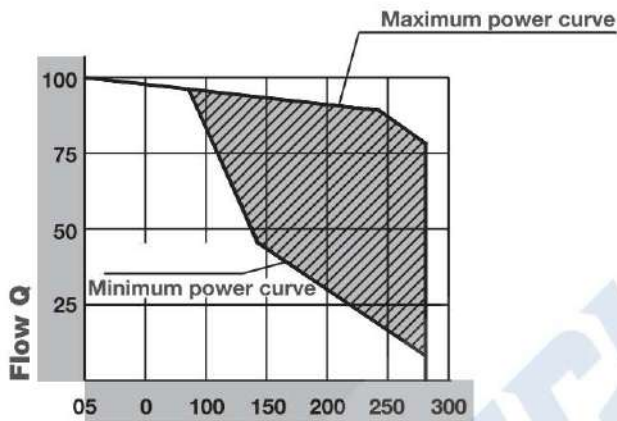

The power characteristic is factory-set, so please enter details in clear text, e.g. 20kW at 1450 rpm (5 hp, 1800 rpm).

Ports	
B	Pressure port
S	Suction port
L, L1	Case drain ports (L1 plugged)
X	Pilot pressure port

Circuit diagram, Sizes 28 to 100

1. Customer supplied

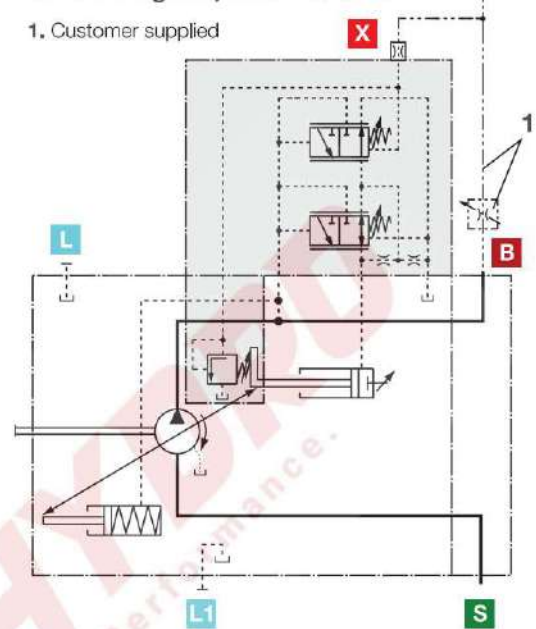

Circuit diagram, Size 140

1. Customer supplied

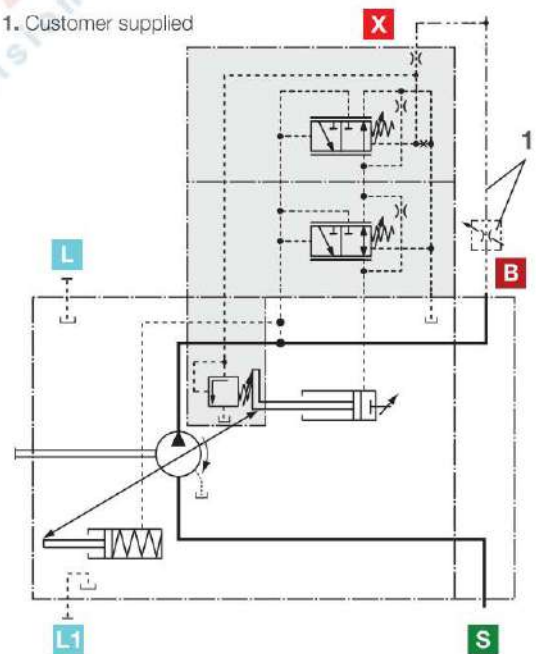

DFLR Controller Data

- For pressure control technical data see DR Pressure Control.
- For flow control technical data see DFR Control.

Size	18	28	45	71	100	140
Start of control	From 80 bar (1,160 psi)					
Pilot oil consumption	Max. approx. 5.5 lpm (1.45 gpm)					

DIMENSIONS DR

Service Ports at Rear; Models 61N00 and 11N00

Sizes 18 to 140

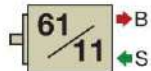

U	61	Rear Ports, UNC Mtg Thread
M	11	Rear Ports, Metric Mtg Thread
	N00	Without Through Drive

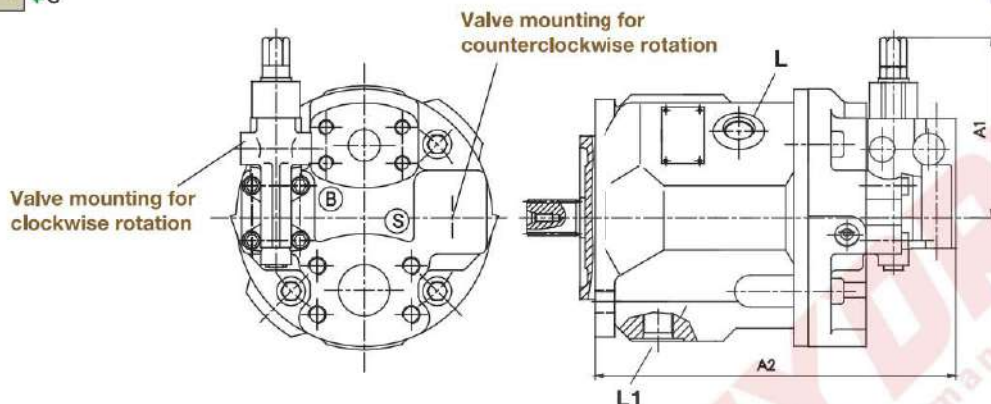

Service Ports at Side; Models 62N00 and 12N00

Sizes 18 to 140

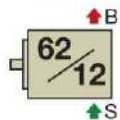

U	62	Side Ports, UNC Mtg Thread
M	12	Side Ports, Metric Mtg Thread
	N00	Without Through Drive

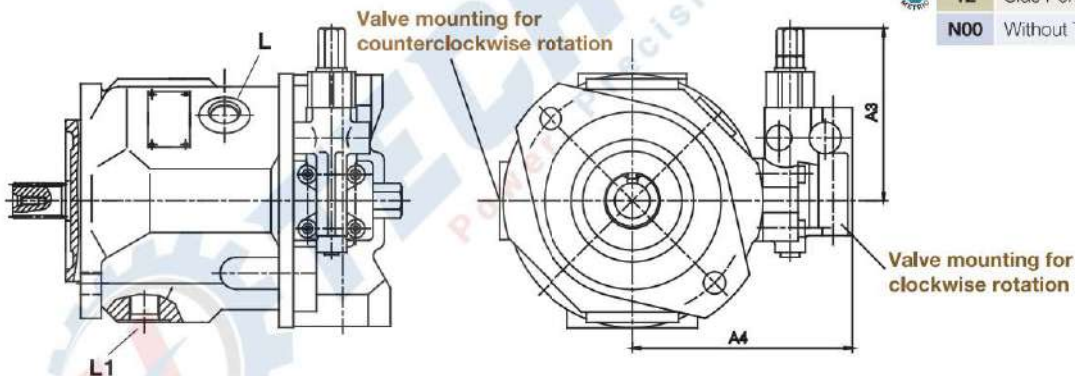

Sizes	Rear Port Models 61/11		Side Port Models 62/12	
	A1 max. mm (in)	A2 mm (in)	A3 max. mm (in)	A4 mm (in)
18	-	-	110 (4.33)	126 (4.96)
28	113 (4.45)	226 (8.90)	110 (4.33)	136 (5.35)
45	110 (4.33)	226 (8.90)	110 (4.33)	146 (5.75)
71	110 (4.33)	279 (10.98)	110 (4.33)	160 (6.3)
100	110 (4.33)	344 (13.54)	110 (4.33)	165 (6.50)
140	126 (4.96)	-	126 (4.96)	170 (6.70)

DIMENSIONS DRG / DFR / DFR1

Service Ports at Rear; Models 61N00 and 11N00

Sizes 18 to 140

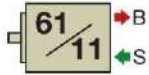

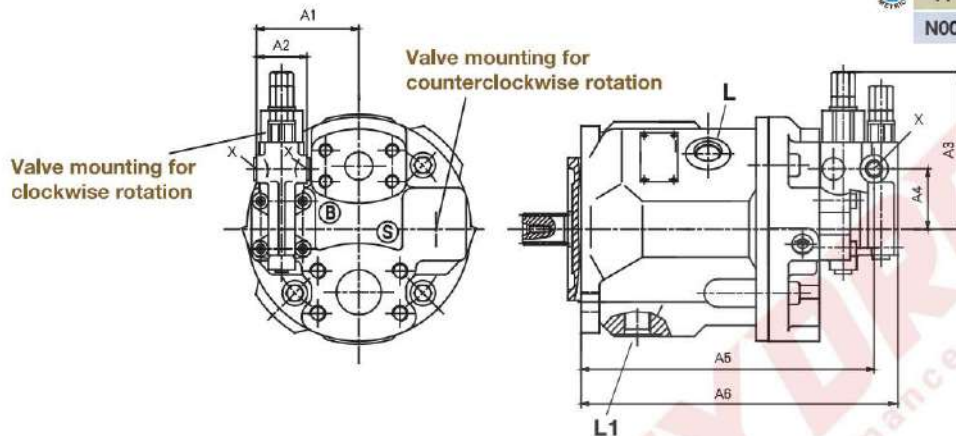

	61	Rear Ports, UNC Mtg Thread
	11	Rear Ports, Metric Mtg Thread
	N00	Without Through Drive

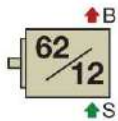

Service Ports at Side; Models 62N00 and 12N00

Sizes 18 to 140



	62	Side Ports, UNC Mtg Thread
	12	Side Ports, Metric Mtg Thread
	N00	Without Through Drive

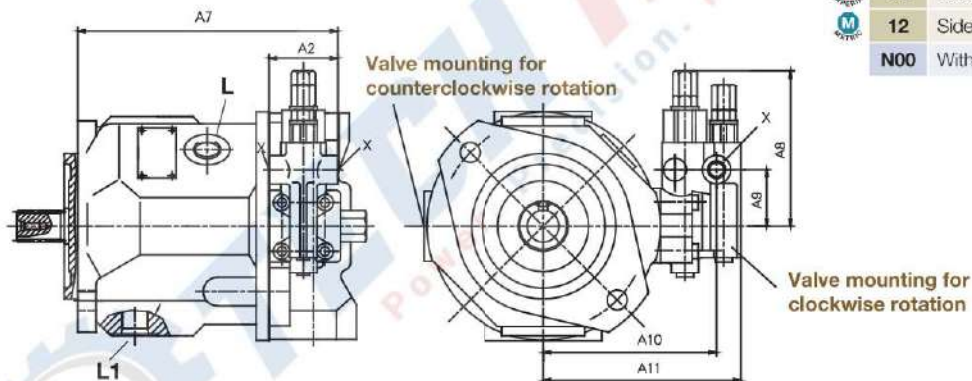

Sizes	A1 mm (in)	A2 mm (in)	A3 mm (in)	A4 mm (in)	A5 mm (in)	A6 mm (in)	A7 mm (in)	A8 mm (in)	A9 mm (in)	A10 mm (in)	A11 mm (in)	X mm (in)
18	-	36 (1.42)	-	-	-	-	166 (6.54)	106 (4.13)	40 (1.57)	109 (4.29)	126 (4.96)	7/16-20UNF-2B
28	73 (2.87)	36 (1.42)	108.5 (4.27)	43 (1.69)	209.2 (8.23)	226.2 (8.9)	176 (6.9)	108.5 (4.27)	40 (1.57)	119 (4.69)	136 (5.35)	7/16-20UNF-2B
45	82 (3.21)	36 (1.42)	108.5 (4.27)	40 (1.57)	229 (8.98)	245 (9.65)	191 (7.5)	108.5 (4.27)	40 (1.57)	129 (5.08)	146 (5.75)	7/16-20UNF-2B
71	91 (3.60)	36 (1.42)	106 (4.17)	42 (1.65)	262 (10.31)	279 (10.98)	219 (8.6)	108.5 (4.27)	40 (1.57)	143 (5.63)	160 (6.30)	7/16-20UNF-2B
100	96.3 (3.79)	36 (1.42)	108.5 (4.27)	40 (1.57)	327 (12.87)	344 (13.54)	287 (11.3)	108.5 (4.27)	40 (1.57)	141 (5.55)	158 (6.22)	7/16-20UNF-2B
140	140 (5.51)	36 (1.42)	-	27 (1.06)	353 (13.9)	379 (14.92)	258 (10.16)	127 (5.0)	27 (1.06)	183 (7.2)	209 (8.23)	9/16-18UNF-2B

DIMENSIONS DFLR

Service Ports at Rear; Models 61N00 and 11N00

Sizes 18 to 140

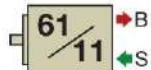

U	61	Rear Ports, UNC Mtg Thread
M	11	Rear Ports, Metric Mtg Thread
	N00	Without Through Drive

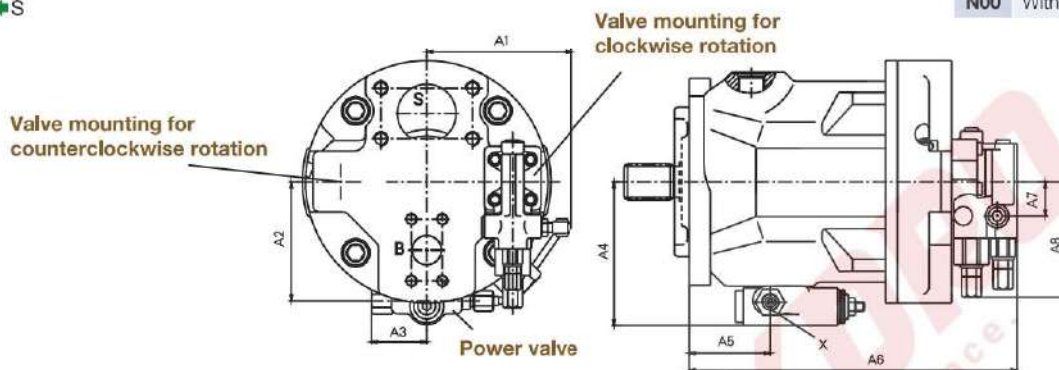

Service Ports at Side; Models 62N00 and 12N00

Sizes 18 to 140

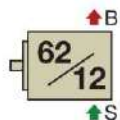

U	62	Side Ports, UNC Mtg Thread
M	12	Side Ports, Metric Mtg Thread
	N00	Without Through Drive

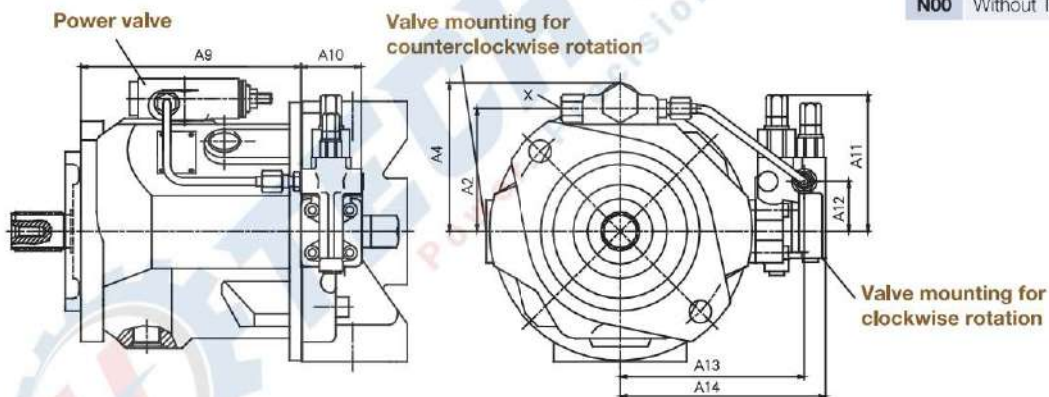

Sizes	A1 mm (in)	A2 mm (in)	A3 mm (in)	A4 mm (in)	A5 mm (in)	A6 mm (in)	A7 mm (in)	A8 mm (in)	A9 mm (in)	A10 mm (in)	A11 mm (in)	A12 mm (in)	A13 mm (in)	A14 mm (in)	X mm (in)
28	120 (4.72)	87.5 (3.44)	47 (1.9)	108.5 (4.27)	48 (1.89)	226.2 (8.9)	43 (1.69)	108.5 (4.27)	40 (1.57)	36 (1.42)	108.5 (4.27)	40 (1.57)	119 (4.69)	136 (5.35)	7/16-20UNF-2B x 0.39H
45	129 (5.08)	92.8 (3.65)	47 (1.9)	112.5 (4.43)	55 (2.17)	245 (9.65)	40 (1.57)	108.5 (4.27)	40 (1.57)	36 (1.42)	108.5 (4.27)	40 (1.57)	129 (5.08)	146 (5.75)	7/16-20UNF-2B x 0.39H
71	139 (5.47)	103.5 (4.07)	47 (1.9)	124 (4.88)	69 (2.72)	279 (10.98)	42 (1.65)	106.5 (4.17)	40 (1.57)	36 (1.42)	108.5 (4.27)	40 (1.57)	143 (5.63)	160 (6.30)	7/16-20UNF-2B x 0.39H
100	145 (5.71)	112.6 (4.43)	47 (1.9)	132.5 (5.22)	110.8 (4.36)	344 (13.54)	40 (1.57)	108.5 (4.27)	40 (1.57)	36 (1.42)	108.5 (4.27)	40 (1.57)	148 (5.83)	165 (6.50)	M14 x 1.5-6H
140	148 (5.83)	140 (5.51)	-	140 (5.51)	99 (3.90)	379 (14.92)	209 (8.23)	163 (7.2)	27 (1.06)	-	127 (5.00)	27 (1.06)	183 (7.29)	209 (8.23)	9/16-18UNF-2B x 0.51H

DIMENSIONS, SIZE 18, SERIES 31

Service Ports on Side; Non Through Drive, Models 62N00 and 12N00 Without Considering Adjustment

TH-A10V(S)O-18

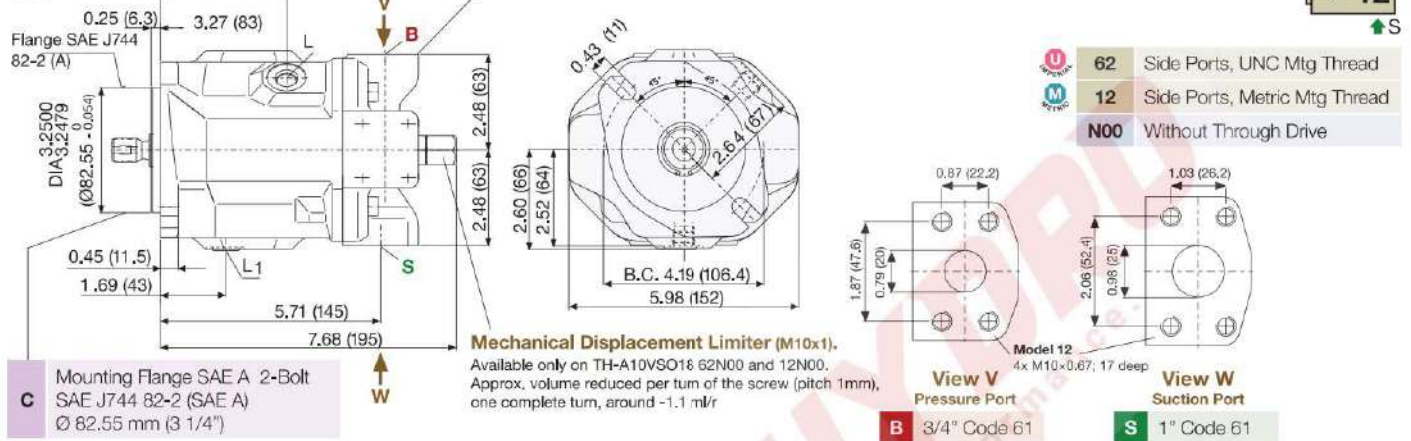

Drive Shafts TH-A10V(S)O-18

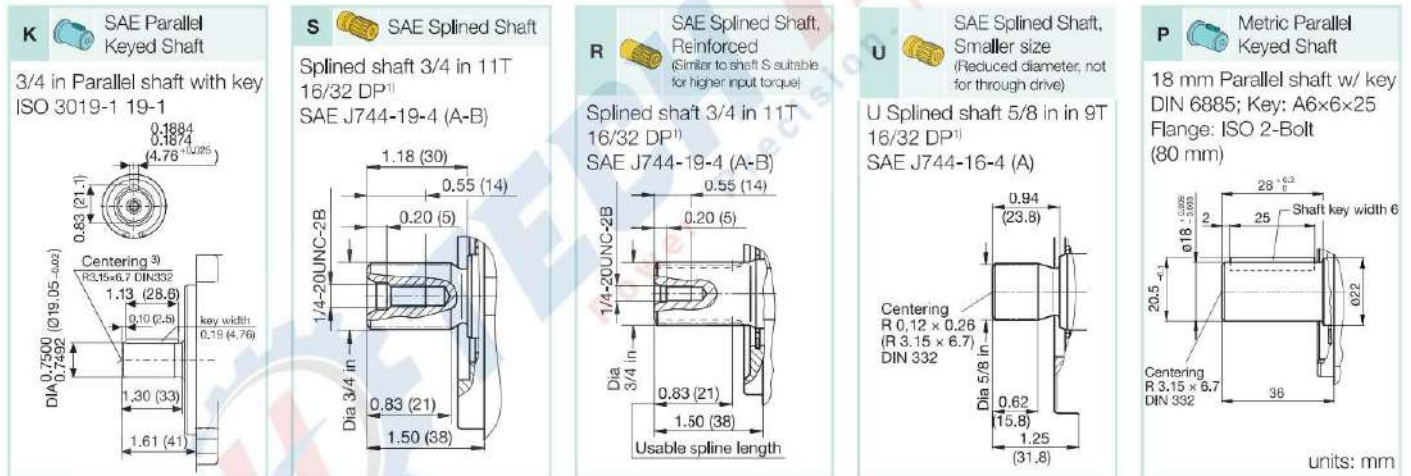

1) ANSI B92.1a-1976, 30° pressure angle, flat root side fit, flank centering, tolerance class 5

Ports TH-A10V(S)O-18

Designation	Port For	Standard	Size	Peak Pressure [psi (bar)]	Tightening Torque Max [lbft (Nm)]	State
B	Pressure port (standard pressure range) Threading in bolt holes	SAE J518 ISO 68	3/4 in (3/4" Code 61) 3/8-16 UNC-2B; 0.79 (20) deep	5100 (350)	29 (40)	O
S	Inlet port (standard pressure range) Threading in bolt holes	SAE J518 ISO 68	1 in (1" Code 61) 3/8-15 UNC-2B; 0.79 (20) deep	75 (5)	29 (40)	O
L, L1	Case drain ports (L1 plugged)	ISO 11926	9/16-18 UNF-2B (SAE-6)	30 (2)	59 (80)	O ¹⁾
X	Pilot pressure port	ISO 11926	7/16-20 UNF-2B; 0.39 (10) deep (SAE-4)	5100 (350)	29 (40)	O
X	Control pressure for DG control	DIN 3852	R 1/4 in	1740 (120)	48 (70)	O

O = Must be connected (plugged on delivery)

1) Depending on the installation position, L or L1 must be connected (also see installation instructions on page 33).

 Imperial  Metric

TECH HYDRO Variable Piston Pump TH-A10VSO series 31 - Rev. C (08/31/2023)

DIMENSIONS, SIZE 28, SERIES 31

Service Ports on Side and Rear; Non Through Drive

Without Considering Adjustment

TH-A10V(S)O-28

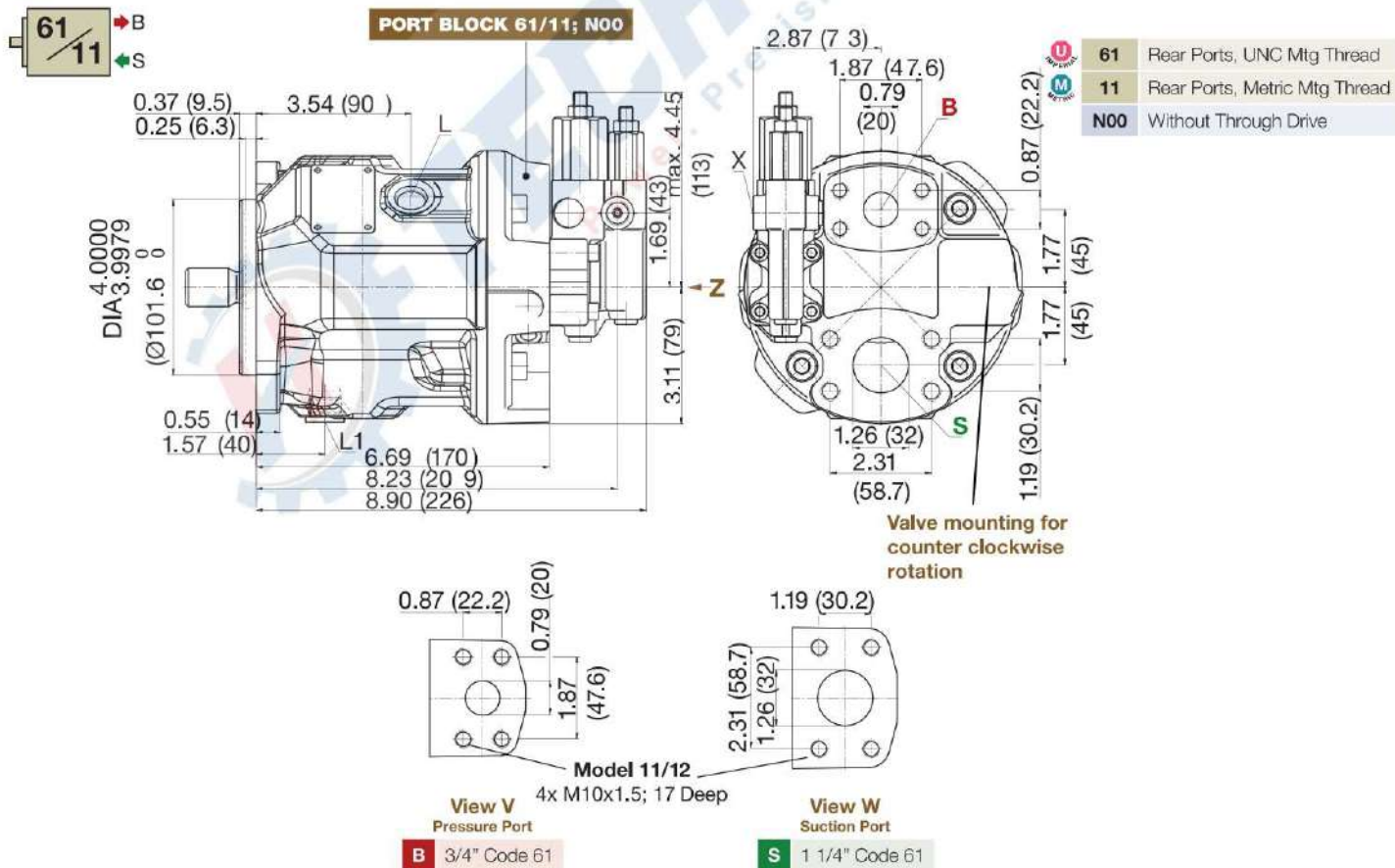
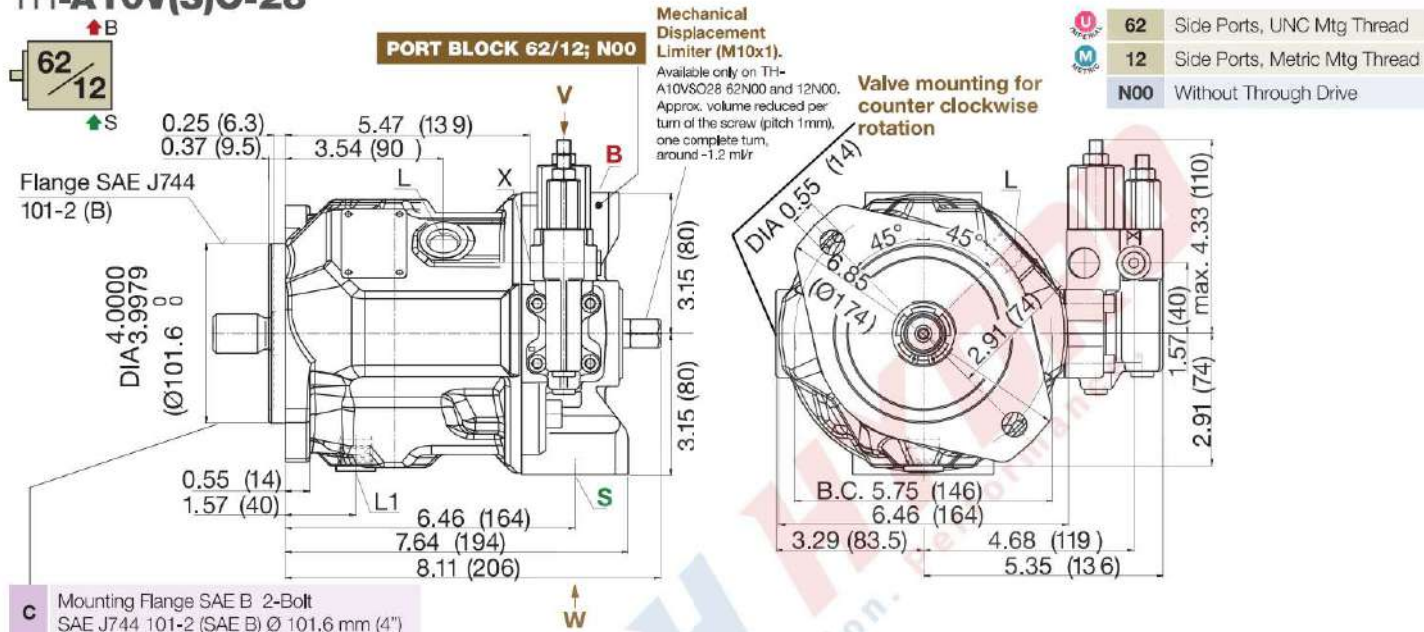

DIMENSIONS, SIZE 28, SERIES 31

Drive Shafts TH-A10V(S)O-28, Metric Mount, and Port Dimensions Without Considering Adjustment

TH-A10V(S)O-28 Drive Shafts

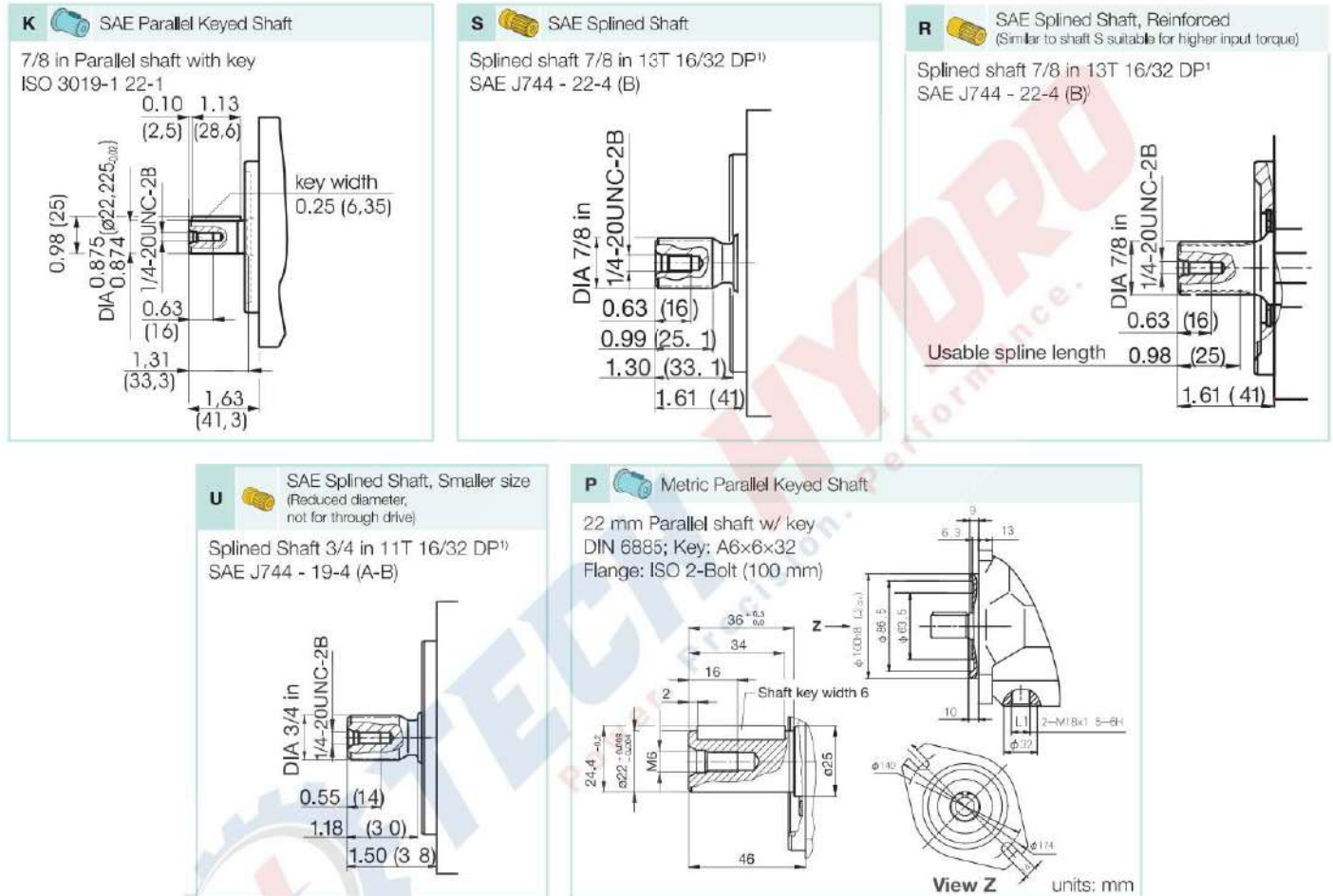

1) ANSI B92.1a-1976, 30° pressure angle, flat root side fit, flank centering, tolerance class 5

Ports TH-A10V(S)O-28

Designation	Port For	Standard	Size	Peak Pressure [psi (bar)]	Tightening Torque Max [lbf (Nm)]	State
B	Pressure port (standard pressure range) Threading in bolt holes	SAE J518 ISO 68	3/4 in (3/4" Code 61) 3/8-16 UNC-2B; 0.79 (20) deep	5100 (350)	29 (40)	O
S	Inlet port (standard pressure range) Threading in bolt holes	SAE J518 ISO 68	1 1/4 in (1 1/4" Code 61) 7/16-14 UNC-2B; 0.94 (24) deep	75 (5)	48 (85)	O
L, L1	Case drain ports (L1 plugged)	ISO 11926	3/4-16 UNF-2B; 0.47 (12) deep (SAE-8)	30 (2)	118 (160)	O ¹⁾
X	Pilot pressure port	ISO 11926	7/16-20UNC-2B; 0.47 (12) deep (SAE-4)	5100 (350)	29 (40)	O
X	Control pressure for DG control	DIN 3852	R 1/4 in	1740 (120)	48 (70)	O

O = Must be connected (plugged on delivery)

1) Depending on the installation position, L or L1 must be connected (also see installation instructions on page 33).

DIMENSIONS, SIZE 45, SERIES 31

Service Ports at Side and Rear; Non Through Drive Without Considering Adjustment



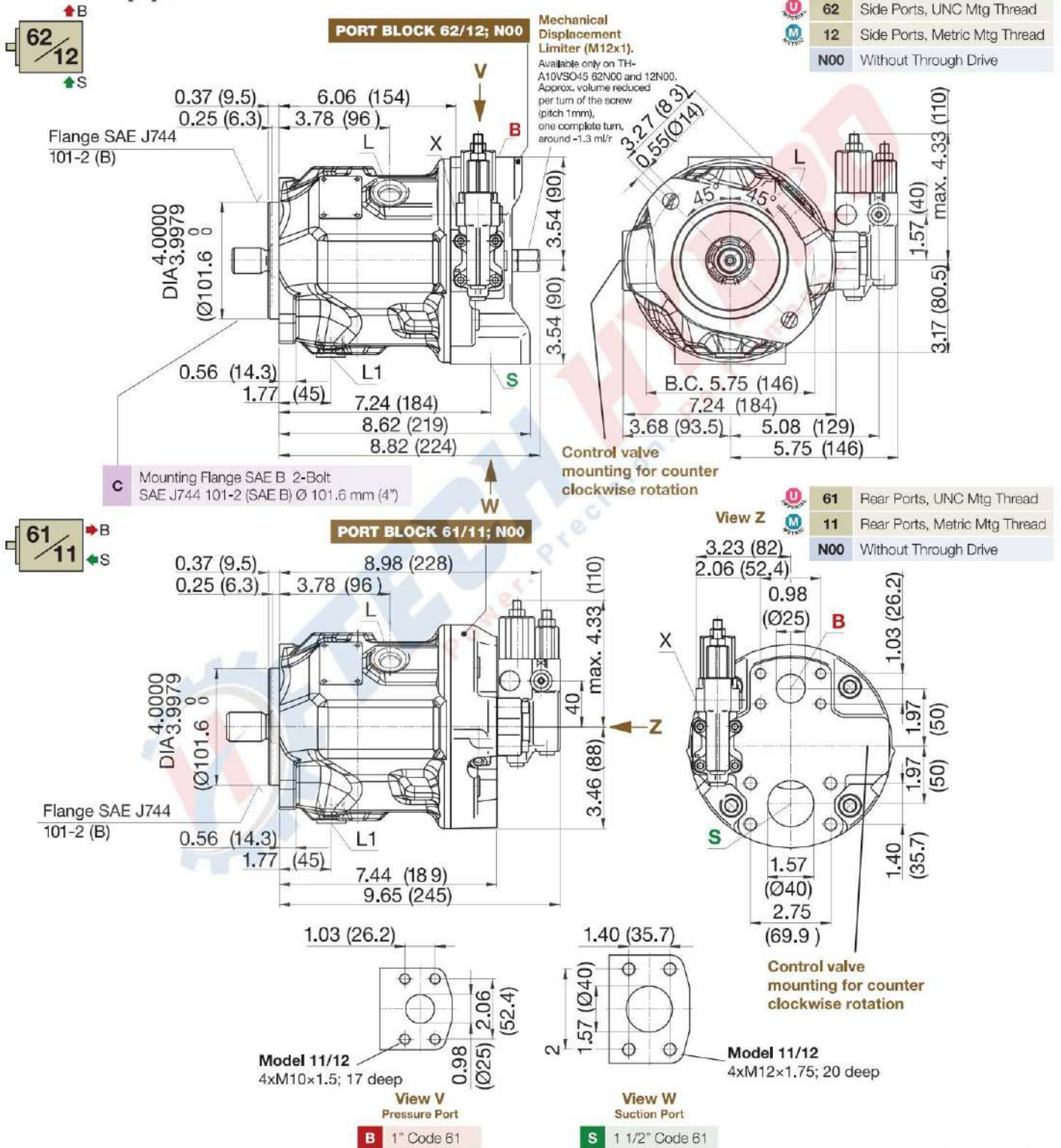





TH-A10V(S)O-45

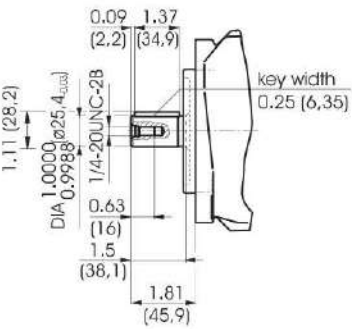

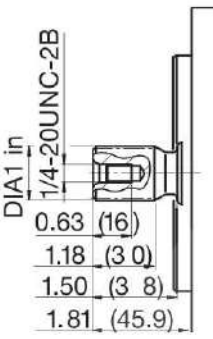
DIMENSIONS, SIZE 45, SERIES 31

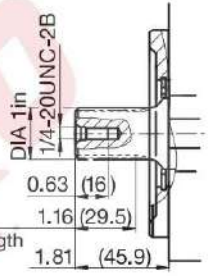
Drive Shafts TH-A10V(S)O-45, Metric Mount, and Port Dimensions

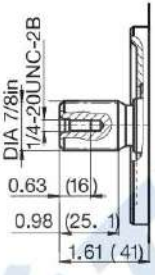
Drive Shafts TH-A10V(S)O-45

<p>K  SAE Parallel Keyed Shaft</p> <p>1 in Parallel shaft with key ISO 3019-1 22-1</p> 	<p>S  SAE Splined Shaft</p> <p>Splined shaft 1 in 15T 16/32 DP¹⁾ SAE J744 - 25-4 (B-B)</p> 	<p>R  SAE Splined Shaft, Reinforced (Similar to shaft S suitable for higher input torque)</p> <p>Splined shaft 1 in 15T 16/32 DP¹⁾ SAE J744 - 25-4 (B-B)</p> 
<p>U  SAE Splined Shaft, Smaller size (Reduced diameter, not for through drive)</p> <p>Splined Shaft 7/8 in 13T 16/32 DP¹⁾ SAE J744 - 22-4 (B)</p> 	<p>P  Metric Parallel Keyed Shaft</p> <p>25 mm Parallel shaft w/ key DIN 6885; Key: A8x7x36 Flange: ISO 2-Bolt (100 mm)</p> 	

1) ANSI B92.1a-1976, 30° pressure angle, flat root side fit, flank centering, tolerance class 5

Ports TH-A10V(S)O-45

Designation	Port For	Standard	Size	Peak Pressure [psi (bar)]	Tightening Torque Max [lbf (Nm)]	State
B	Pressure port (standard pressure range) Threading in bolt holes	SAE J518 ISO 68	1 in (1" Code 61) 3/8-16 UNC-2B; 0.71 (17) deep	5100 (350)	29 (40)	O
S	Inlet port (standard pressure range) Threading in bolt holes	SAE J518 ISO 68	1 1/2 in (1 1/2" Code 61) 1/2-13 UNC-2N; 0.87 (22) deep	75 (5)	66 (90)	O
L, L1	Case drain ports (L1 plugged)	ISO 11926	7/8-14 UNF-2B (SAE-10)	30 (2)	177 (240)	O ¹⁾
X	Pilot pressure port	ISO 11926	7/16-20 UNF-2B; 0.39 (10) deep (SAE-4)	5100 (350)	29 (40)	O
X	Control pressure for DG control	DIN 3852	R 1/4 in	1740 (120)	48 (70)	O

O = Must be connected (plugged on delivery)

1) Depending on the installation position, L or L1 must be connected (also see installation instructions on page 33).

DIMENSIONS, SIZE 71, SERIES 31

Service Ports on Side and Rear; Non Through Drive Without Considering Adjustment

TH-A10V(S)O-71

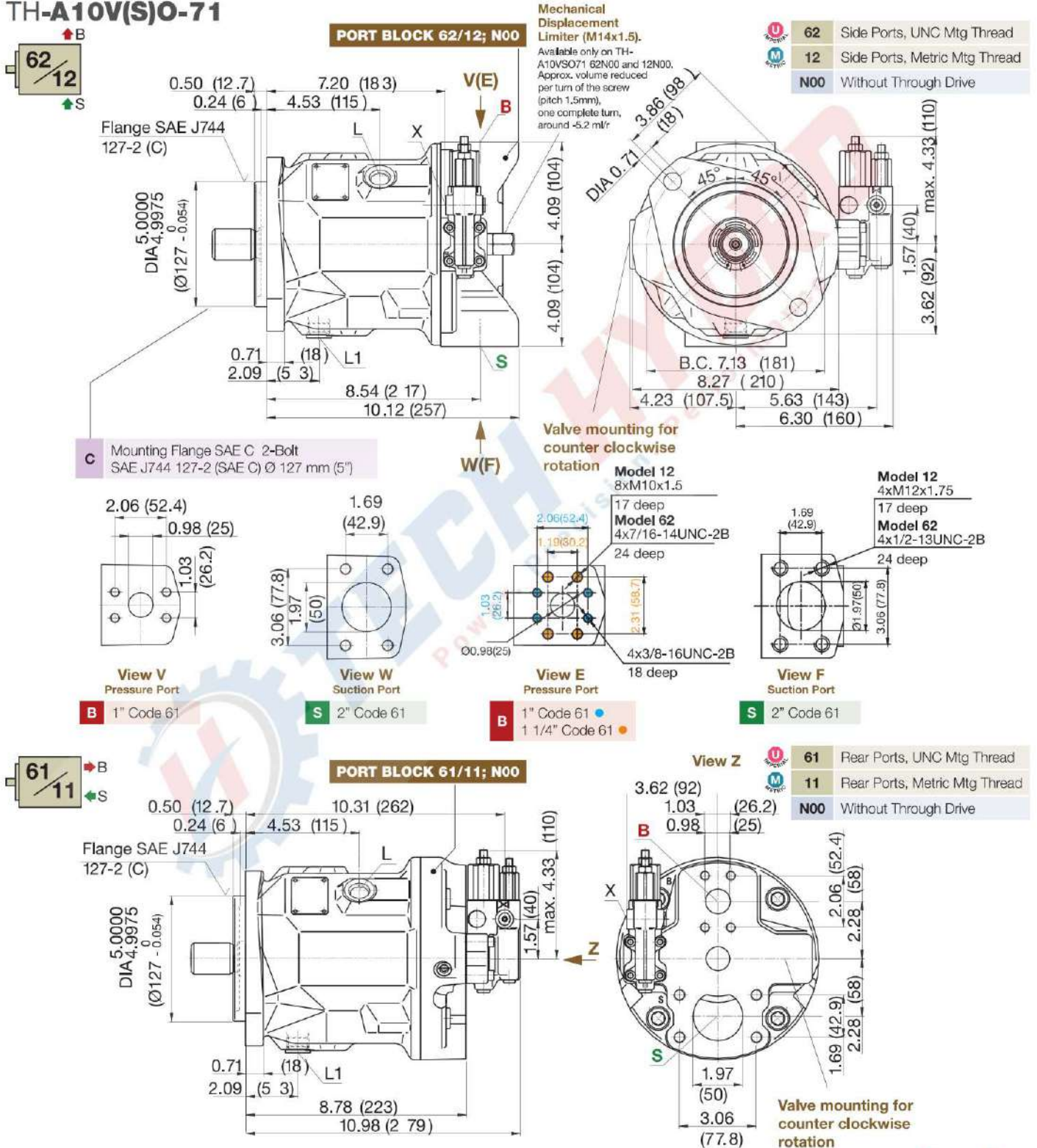

DIMENSIONS, SIZE 71, SERIES 31

Drive Shafts TH-A10V(S)O-71, Metric Mount, and Port

Dimensions

Drive Shafts TH-A10V(S)O-71

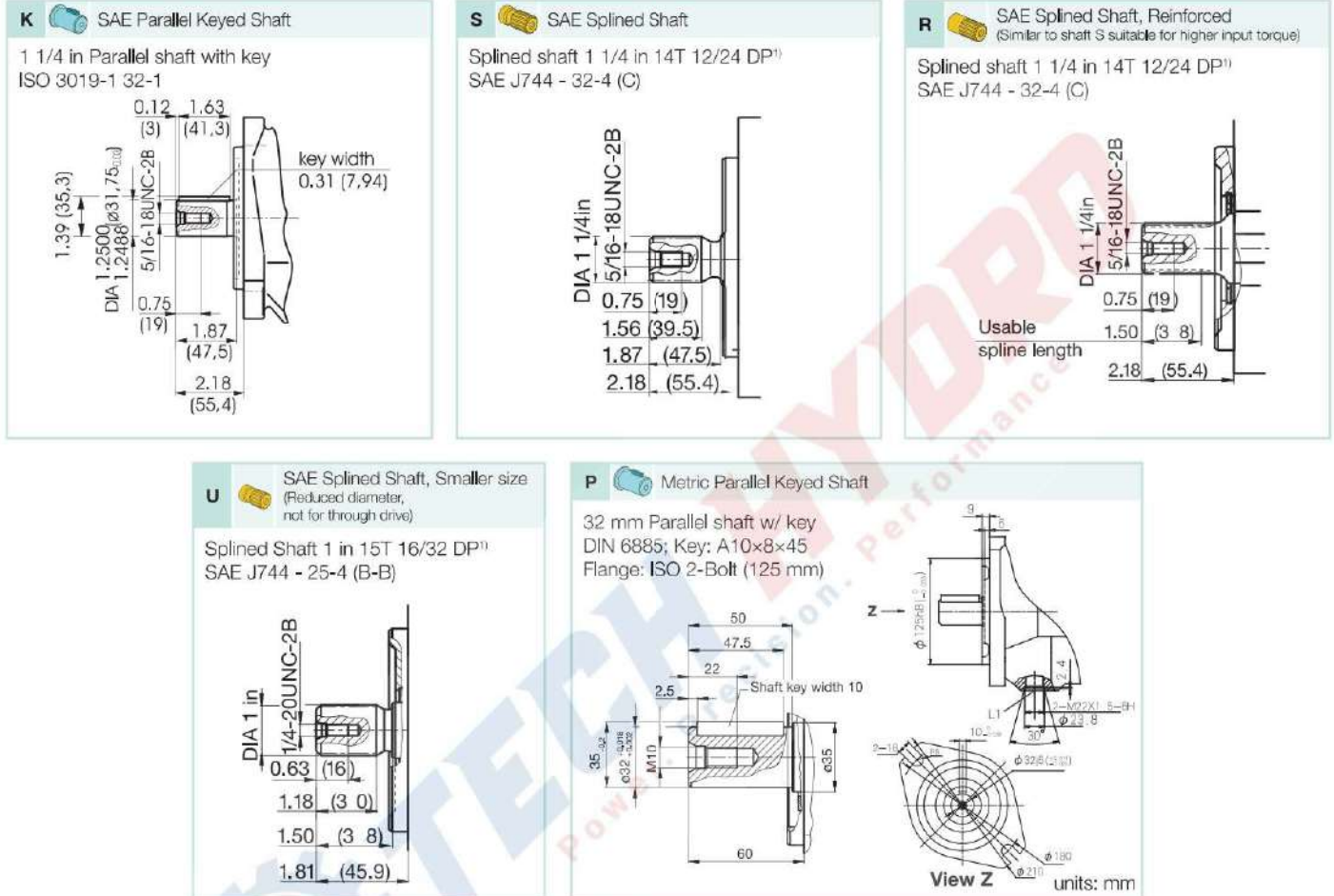

1) ANSI B92.1a-1976, 30° pressure angle, flat root side fit, flank centering, tolerance class 5

Ports TH-A10V(S)O-71

Designation	Port For	Standard	Size	Peak Pressure [psi (bar)]	Tightening Torque Max [lbf (Nm)]	State
B	Pressure port (standard pressure range) Threading in bolt holes	SAE J518 ISO 68	1 in (1" Code 61) ● 3/8-16 UNC-2B; 0.71 (18) deep 1 1/4 (1 1/4" Code 61) ● 7/16-14 UNC-2B; 0.94 (24) deep	5100 (350)	29 (40)	O
S	Inlet port (standard pressure range) Threading in bolt holes	SAE J518 ISO 68	2 in (2" Code 61) 1/2-13 UNC-2B; 0.87 (22) deep	75 (5)	66 (90)	O
L, L1	Case drain ports (L1 plugged)	ISO 11926	7/8-14 UNF-2B (SAE-10)	30 (2)	177 (240)	O ¹⁾
X	Pilot pressure port	ISO 11926	7/8-14 UNF-2B; 0.39 (10) deep (SAE-4)	5100 (350)	29 (40)	O
X	Control pressure for DG control	DIN 3852	R 1/4 in	1740 (120)	48 (70)	O

O = Must be connected (plugged on delivery)

1) Depending on the installation position, L or L1 must be connected (also see installation instructions on page 33).

DIMENSIONS, SIZE 100, SERIES 31

Service Ports on Side and Rear; Non Through Drive Without Considering Adjustment

TH-A10V(S)O-100

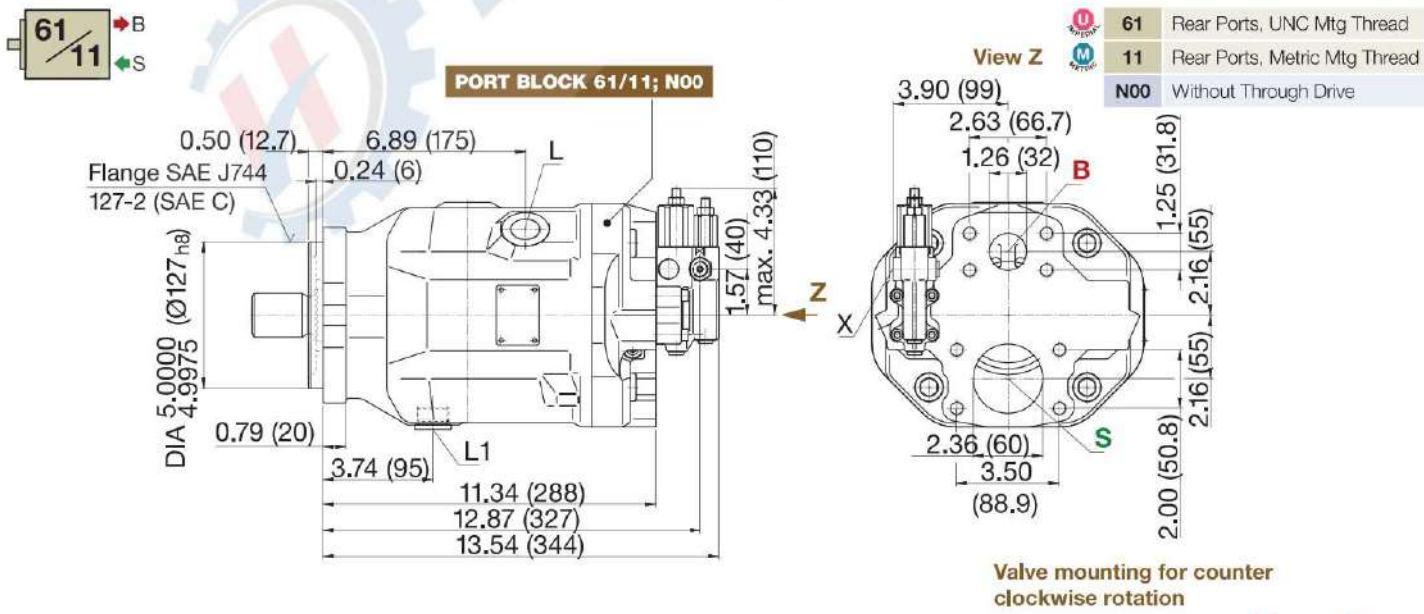
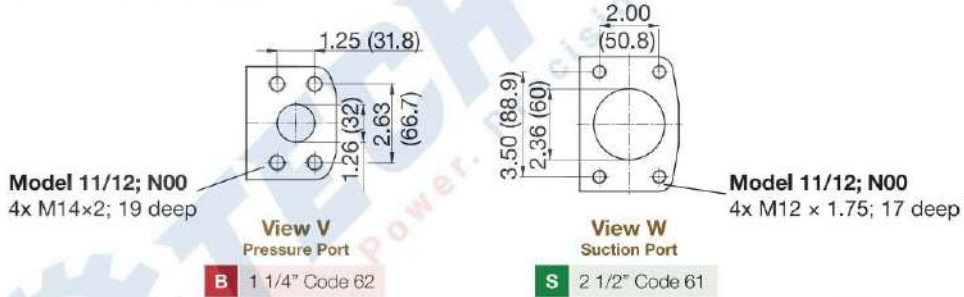
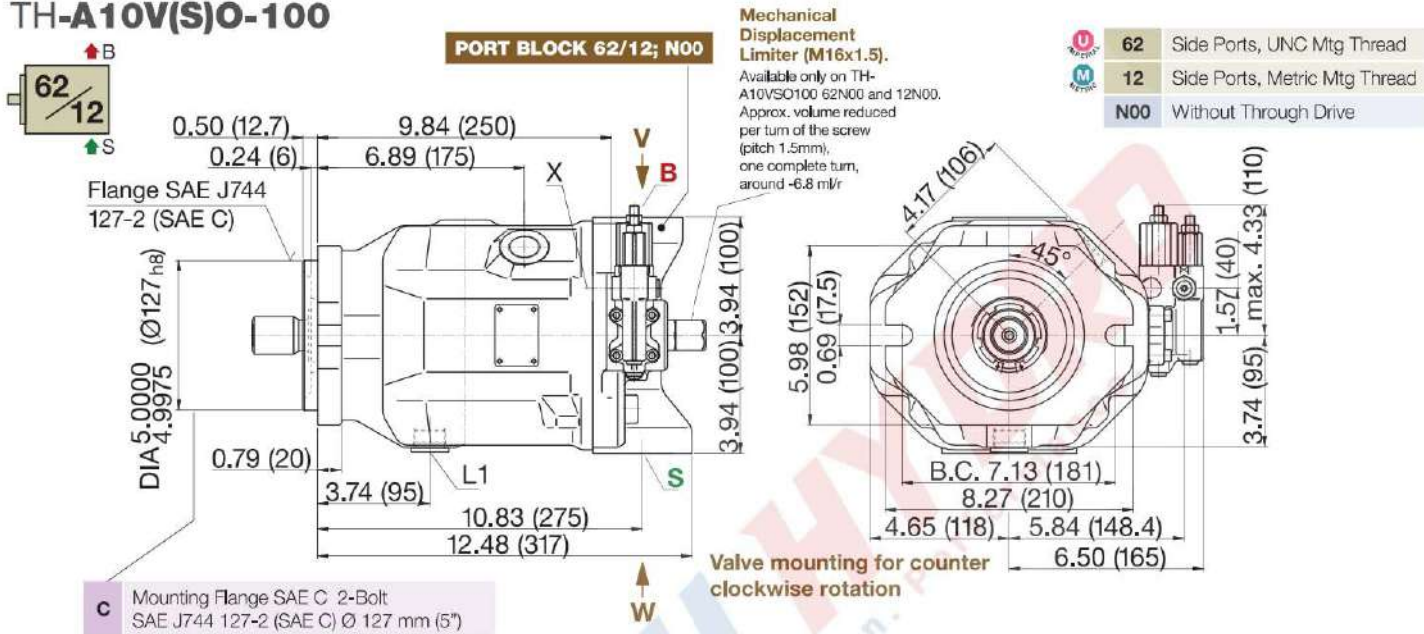

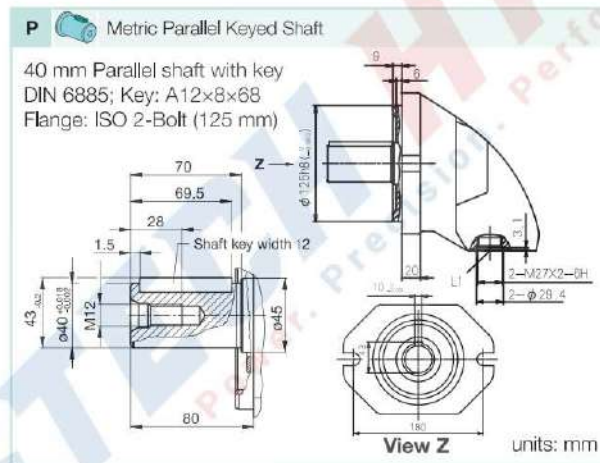
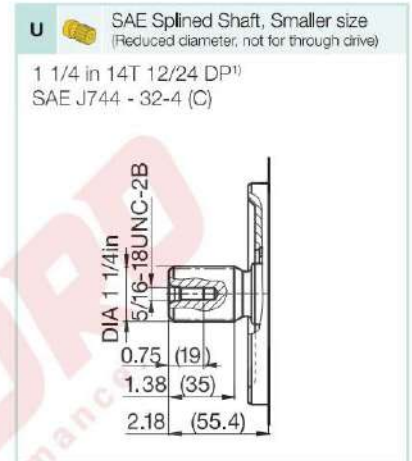
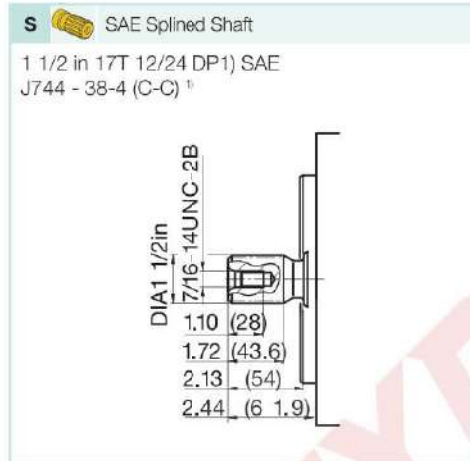
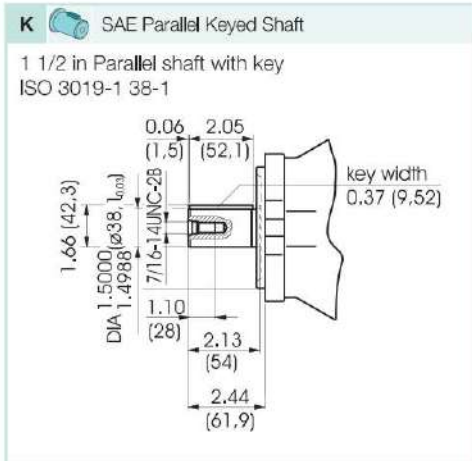
DIMENSIONS, SIZE 100, SERIES 31
Drive Shafts TH-A10V(S)O-100

1) ANSI B92.1a-1976, 30° pressure angle, flat root side fit, flank centering, tolerance class 5

Ports TH-A10V(S)O-100

Designation	Port For	Standard	Size	Peak Pressure [psi (bar)]	Tightening Torque Max [lbft (Nm)]	State
B	Pressure port (standard pressure range) Threading in bolt holes	SAE J518 ISO 68	1 1/4 in (1 1/4" Code 62) 1/2-13 UNC-2B; 0.75 (19) deep	5100 (350)	66 (90)	O
S	Inlet port (standard pressure range) Threading in bolt holes	SAE J518 ISO 68	2 1/2 in (2 1/2" Code 61) 1/2-13 UNC-2B; 1.06 (17) deep	75 (5)	66 (90)	O
L, L1	Case drain ports (L1 plugged)	ISO 11926	1 1/16-12 UNF-2B (SAE-12)	30 (2)	265 (360)	O ¹⁾
X	Pilot pressure port	ISO 11926	7/16-20 UNF-2B; 0.39 (10) deep (SAE-4)	5100 (350)	59 (80)	O
X	Control pressure for DG control	DIN 3852	R 1/4 in	1740 (120)	59 (80)	O

O = Must be connected (plugged on delivery)

1) Depending on the installation position, L or L1 must be connected (also see installation instructions on page 33).

DIMENSIONS, SIZE 140, SERIES 31

Service Ports on Side; Non Through drive, Models 62N00 and 12N00

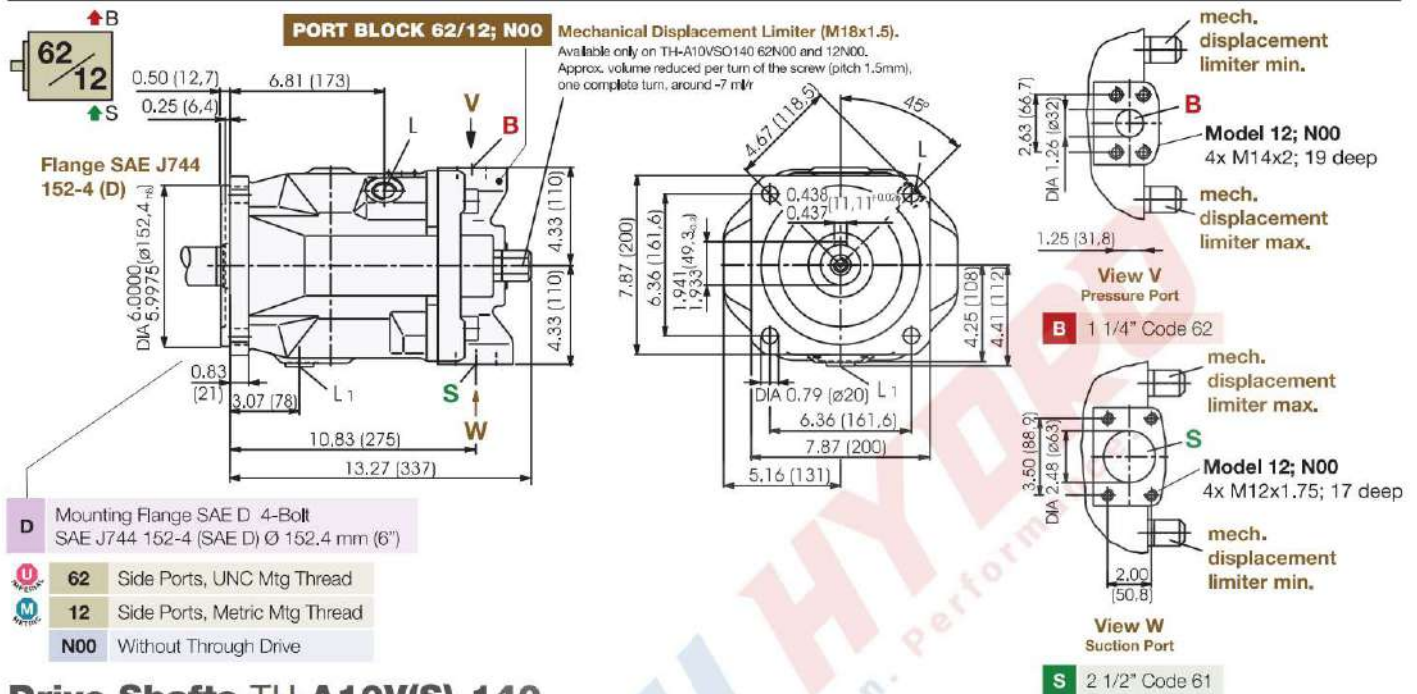

Drive Shafts TH-A10V(S)-140

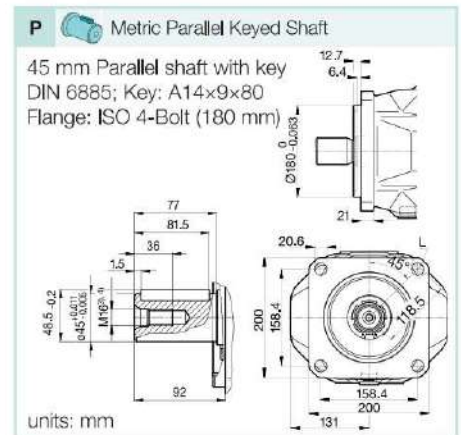
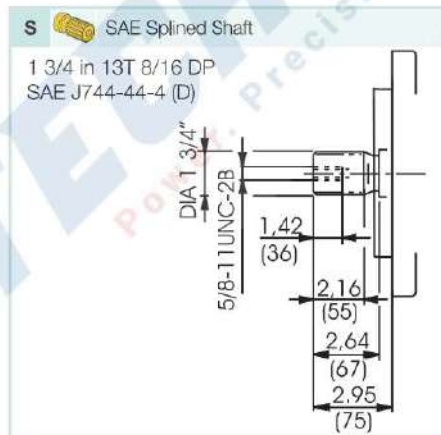
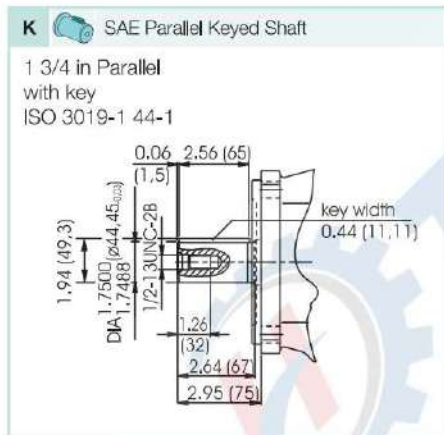

Ports TH-A10V(S)-140

Designation	Port For	Standard	Size	Peak Pressure [psi (bar)]	Tightening Torque Max [lbf (Nm)]	State
B	Pressure port (standard pressure range) Threading in bolt holes	SAE J518 ISO 68	1 1/4 in (1 1/4" Code 62) 1/2-13 UNC-2B; 0.75 (24) deep	5100 (350)	66 (90)	O
S	Inlet port (standard pressure range) Threading in bolt holes	SAE J518 ISO 68	2 1/2 in (2 1/2" Code 61) 1/2-13 UNC-2B; 0.94 (24) deep	75 (5)	66 (90)	O
L, L1	Case drain ports (L1 plugged)	ISO 11926	1 1/16-12 UNF-2B (SAE-12)	30 (2)	265 (360)	O ¹⁾
X	Pilot pressure port	ISO 11926	9/16-18 UNF-2B; 0.51 (13) deep (SAE-4)	5100 (350)	59 (80)	O
X	Control pressure for DG control	DIN 3852	M14 x 1.5; 0.47 (12) deep	1740 (120)	59 (80)	O

O = Must be connected (plugged on delivery)

1) Depending on the installation position, L or L1 must be connected (also see installation instructions on page 33).

TECH HYDRO Variable Piston Pump TH-A10VSO series 31 - Rev. C (08/31/2023)

Imperial Metric

THROUGH DRIVE MOUNTING OPTIONS

Shaft Torque Data

Axial piston units TH-A10V can be supplied with a through drive as shown in the ordering code on page 32. The type of through drive is determined by codes (K40-K...). If the combination pump is not mounted in the factory, the simple type code is sufficient.

Maximum permissible input and through drive torque

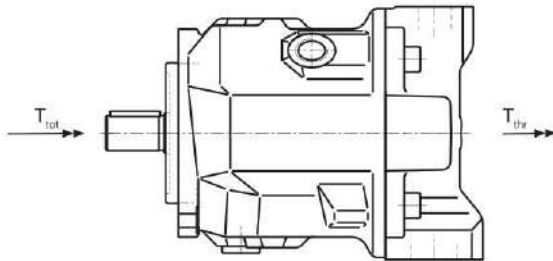

The drive torques for pump 1 and pump 2 can be split up as required. However the max. permissible input torque T_{tot} as well as the max. permissible through drive torque T_{thr} may not be exceeded.

Max. perm. input torque T_{tot}	18	28	45	71	100	140
With shaft U T_{tot} lb.ft (Nm)	43 (59)	- (-)	139 (188)	- (-)	439 (595)	- (-)
With shaft K T_{tot} lb.ft (Nm)	77 (104)	107 (145)	156 (212)	319 (433)	553 (750)	875 (1186)
With shaft S T_{tot} lb.ft (Nm)	92 (124)	146 (198)	235 (319)	462 (626)	814 (1104)	1195 (1620)
With shaft R T_{tot} lb.ft (Nm)	111 (150)	166 (225)	295 (400)	475 (644)	- (-)	- (-)
Max. perm. through drive torque T_{thr}	18	28	45	71	100	140
With shaft K T_{thr} lb.ft (Nm)	77 (104)	107 (145)	156 (212)	319 (433)	553 (750)	875 (1186)
With shaft S T_{thr} lb.ft (Nm)	80 (108)	118 (160)	235 (319)	363 (492)	574 (778)	934 (1266)
With shaft R T_{thr} lb.ft (Nm)	88 (120)	130 (176)	269 (365)	404 (548)	- (-)	- (-)
Keyed shaft $T_{thr \text{ keyed}}$ lb.ft (Nm)	53 (72)	83 (112)	132 (178)	209 (283)	293 (398)	411 (557)

T_{tot} = max. permissible input torque pump 1

T_{thr} = max. permissible through drive torque

$T_{thr \text{ keyed}}$ = max. permissible through drive torque at through drive to keyed shaft

Permissible overhang moment

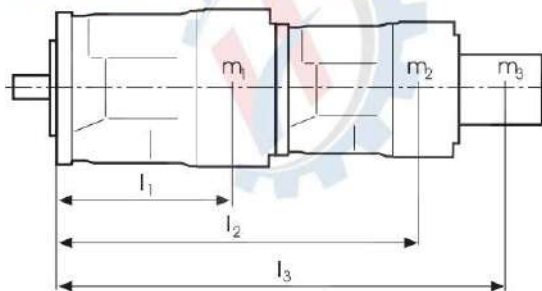

m_1, m_2, m_3 weight of pump [lbs (kg)]
 l_1, l_2, l_3 distance to center of gravity [in (mm)]

$$T_m = (m_1 \cdot l_1 + m_2 \cdot l_2 + m_3 \cdot l_3) \cdot \frac{1}{12} \quad [\text{lb.ft.}]$$

$$\dots \cdot \frac{1}{102} \quad [\text{Nm}]$$

Size		18	28	45	71	100	140
Permissible overhang moment T_m	lb.ft. (Nm)	369 (500)	649 (880)	1010 (1370)	1593 (2160)	2213 (3000)	3319 (4500)
at dyn. acceleration 10g = 98.1 m/s ²	T_m lb.ft. (Nm)	37 (50)	65 (88)	101 (137)	159 (216)	221 (300)	332 (450)
Weight	m lbs (kg)	26.5 (12)	33 (15)	46 (21)	73 (33)	99 (45)	132 (60)
Distance to center of gravity	l_1 in (mm)	3.54 (90)	4.33 (110)	5.12 (130)	5.91 (150)	6.30 (160)	6.30 (160)

THROUGH DRIVE MOUNTING OPTIONS

Through Drives - TH-A10V		Code	Mounting Options - 2nd Pump			Available on size
Flange SAE J744	Hub Keyed		TH-A10V/SO.../31... size shaft	TH-A10V/SO.../52... size shaft	Gear Pump	
82-2 (A)	keyed (A-B)	K40	18 (K)	10 (K)	-	18-100
101-2 (B)	keyed (B)	K03	28 (K)	28 (K)	-	28-140
101-2 (B-B)	keyed (B-B)	K05	45 (K)	60, 45 (K)	-	45-140
127-2 (C)	keyed (C)	K08	71 (K)	-	-	71-140
127-2 (C)	keyed (C)	K38	100 (K)	85 (K)	-	100-140
152-4 (D)	keyed (D)	K21	140 (K)	-	-	140

SAE J744	Splined					
82-2 (A)	5/8 in (A)	K01	18 (U)	-	Size F	18-140
82-2 (A)	3/4 in (A-B)	K52	18 (S, R)	10 (S)	-	18-140
101-2 (B)	7/8 in (B)	K68	28 (S, R)	28 (S, R)	Size N, G	28-140
		K02	45 (U) ¹⁾	45 (U) ¹⁾		
101-2 (B)	1 in (B-B)	K04	45 (S, R)	45 (S, R) 60 (U) ²⁾	-	45-140
127-2 (C)	1 1/4 in (C)	K07	71 (S, R) 100 (U) ³⁾	85 (U) ³⁾	-	71-140
127-2 (C)	1 1/2 in (C-C)	K24	100 (S)	85 (S)	-	100-140
152-4 (D)	1 3/4 in (D)	K17	140 (S)	-	-	140

¹⁾ Not with K68 through drive on main pump size 28

²⁾ Not with K04 through drive on main pump size 45

³⁾ Not with K07 through drive on main pump size 71

DIMENSIONS OF THROUGH DRIVES

K01 Flange - SAE J744 82-2 (SAE A) Ø 82.55 mm

K01 Mounting Flange 82-2 (SAE-A) Hub for splined shaft¹⁾ 5/8 in 9T 16/32DP (SAE A)

Can use with TH-A10V18(S,R)

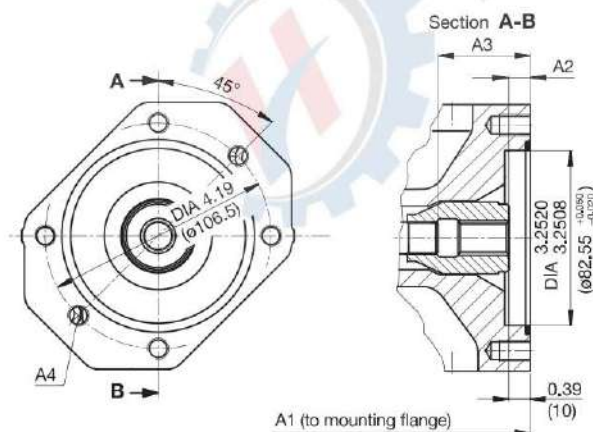

Size	A1	A2	A3	A4 ²⁾
18	7.17 (182)	0.39 (10)	1.70 (43.3)	M10; 0.57 (14.5) deep
28	8.03 (204)	0.39 (10)	1.33 (33.7)	M10; 0.63 (16) deep
45	9.02 (229)	0.42 (10.7)	2.10 (53.4)	M10; 0.63 (16) deep
71	10.50 (267)	0.46 (11.8)	2.41 (61.3)	M10; 0.79 (20) deep
100	13.30 (338)	0.41 (10.5)	2.56 (65)	M10; 0.63 (16) deep
140	13.80 (350)	0.43 (10.8)	3.04 (77.3)	M10; 0.63 (16) deep

1) According to ANSI B92.1a, 30° pressure angle, flat root, side fit, tolerance class 5

2) Thread according to DIN 13, see instruction manual for maximum tightening torques.

DIMENSIONS OF THROUGH DRIVES

K52 Flange - SAE J744 82-2 (SAE A) Ø 82.55 mm

K52 Mounting Flange 82-2 (SAE-A) Hub for splined shaft¹⁾ 3/4 in 11T 16/32DP (SAE A-B)

Can use with TH-A10V18(S,R)

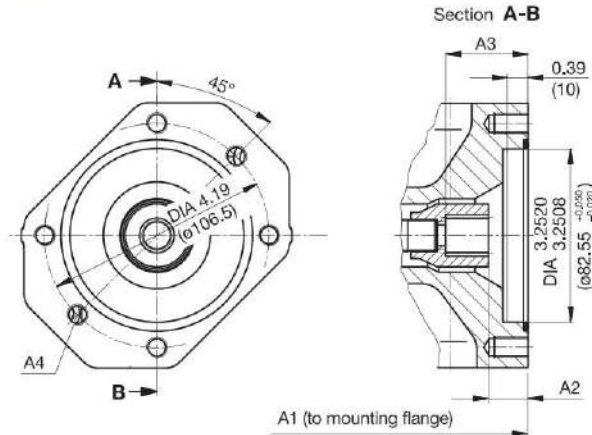

Size	A1	A2	A3	A4 ²⁾
18	7.17 (182)	0.74 (18.8)	1.52 (38.7)	M10; 0.57 (14.5) deep
28	8.03 (204)	0.74 (18.8)	1.52 (38.7)	M10; 0.63 (16) deep
45	9.02 (229)	0.74 (18.9)	1.52 (38.7)	M10; 0.63 (16) deep
71	10.50 (267)	0.84 (21.3)	1.63 (41.4)	M10; 0.79 (20) deep
100	13.30 (338)	0.75 (19)	1.53 (38.9)	M10; 0.63 (16) deep
140	13.80 (350)	0.74 (18.9)	1.52 (38.6)	M10; 0.63 (16) deep

- 1) According to ANSI B92.1a, 30° pressure angle, flat root, side fit, tolerance class 5
- 2) Thread according to DIN 13, see instruction manual for maximum tightening torques.

K68 Flange - SAE J744 101-2 (SAE B) Ø 101.6 mm

K68 Mounting Flange 101-2 (SAE B) Hub for splined shaft¹⁾ 7/8 in 13T 16/32DP (SAE B)

Can use with TH-A10V28(S,R), 45(U,W)

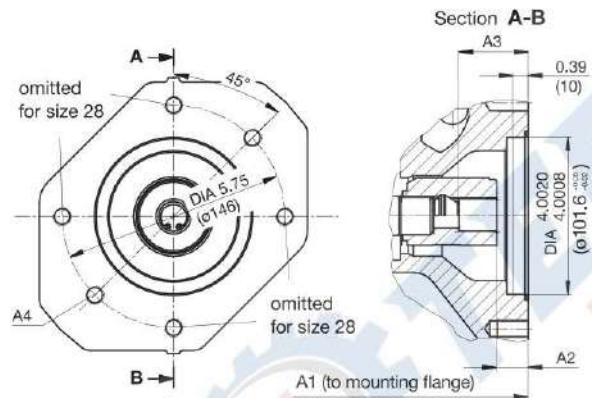

Size	A1	A2	A3	A4 ²⁾
28	8.03 (204)	0.70 (17.8)	1.64 (41.7)	M12; ³⁾
45	9.02 (229)	0.70 (17.9)	1.64 (41.7)	M12; 0.71 (18) deep
71	10.50 (267)	0.80 (20.3)	1.76 (44.7)	M12; 0.79 (20) deep
100	13.30 (338)	0.71 (18)	1.65 (41.9)	M12; 0.79 (20) deep
140	13.80 (350)	0.70 (17.8)	1.64 (41.6)	M12; 0.79 (20) deep

- 1) According to ANSI B92.1a, 30° pressure angle, flat root, side fit, tolerance class 5
- 2) Thread according to DIN 13, see instruction manual for maximum tightening torques.
- 3) Continuous

K04 Flange - SAE J744 101-2 (SAE B) Ø 101.6 mm

K04 Mounting Flange 101-2 (SAE B) Hub for splined shaft¹⁾ 1 in 15T 16/32DP (SAE B-B)

TH-A10V45(S,R)

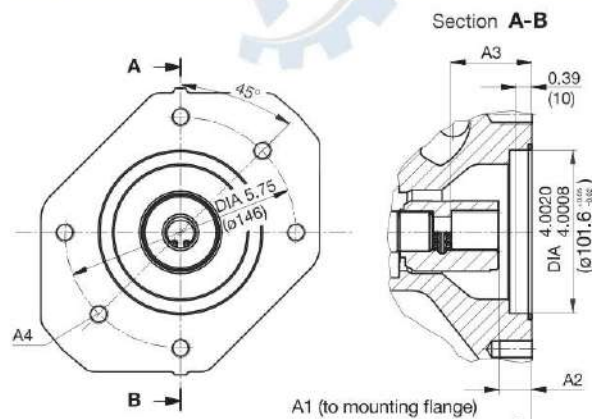

Size	A1	A2	A3	A4 ²⁾
45	9.02 (229)	0.72 (18.4)	1.84 (46.7)	M12; 0.71 (18) deep
71	10.50 (267)	0.82 (20.8)	1.93 (49.1)	M12; 0.79 (20) deep
100	13.30 (338)	0.72 (18.2)	1.83 (46.6)	M12; 0.79 (20) deep
140	13.80 (350)	0.72 (18.3)	1.81 (45.1)	M12; 0.79 (20) deep

- 1) According to ANSI B92.1a, 30° pressure angle, flat root, side fit, tolerance class 5
- 2) Thread according to DIN 13, see instruction manual for maximum tightening torques.

DIMENSIONS OF THROUGH DRIVES

K07 Flange - SAE J744 127-2 (SAE C) Ø 127 mm

K07 Mounting Flange 127-2 (SAE C) Hub for splined shaft¹⁾ 1 1/4 in 14T 12/24DP (SAE C)

Can use with TH-A10V71(S,R), 100(U,W)

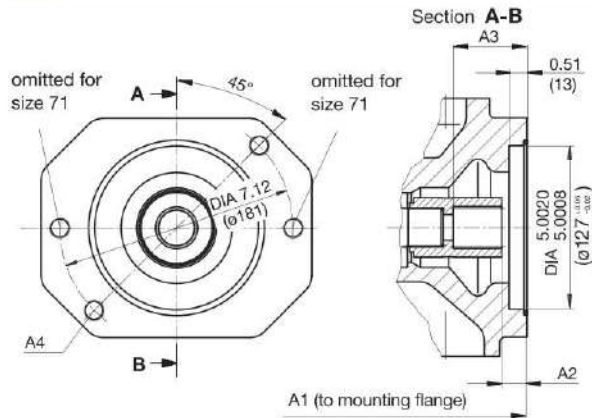

Size	A1	A2	A3	A4 ²⁾
71	10.50 (267)	0.89 (21.8)	2.31 (58.6)	M16; ³⁾
100	13.30 (338)	0.77 (19.5)	2.22 (56.4)	M16; ³⁾
140	13.80 (350)	0.76 (19.3)	2.21 (56.1)	M16; 0.94 (24) deep

- 1) According to ANSI B92.1a, 30° pressure angle, flat root, side fit, tolerance class 5
- 2) Thread according to DIN 13, see instruction manual for maximum tightening torques.
- 3) Continuous

K24 Flange - SAE J744 127-2 (SAE C) Ø 127 mm

K24 Mounting Flange 127-2 (SAE C) Hub for splined shaft¹⁾ 1 1/2 in 17T 12/24DP (SAE C-C)

Can use with TH-A10V100(S,R)

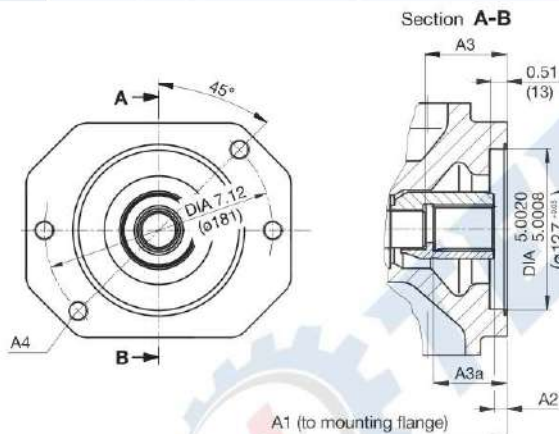

Size	A1	A2	A3	A3a	A4 ²⁾
100	13.30 (338)	0.39 (9.9)	2.56 (65)	-	M16; ³⁾
140	13.80 (350)	0.38 (9.7)	-	2.72 (69.1)	M16; 0.94 (24) deep

- 1) According to ANSI B92.1a, 30° pressure angle, flat root, side fit, tolerance class 5
- 2) Thread according to DIN 13, see instruction manual for maximum tightening torques.
- 3) Continuous

K17 Flange - SAE J744 152-4 (SAE D) Ø 152.4 mm

K17 Mounting Flange 152-4 (SAE D) Hub for splined shaft¹⁾ 1 3/4 in 13T 8/16DP (SAE D)

Can use with TH-A10V140(S,R)

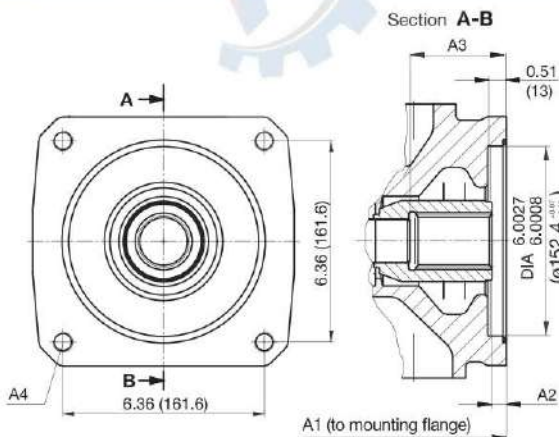

Size	A1	A2	A3	A4 ²⁾
140	13.80 (350) ³⁾	0.53 (11)	3.04 (77.3)	M16; ³⁾

Only available with housing with mounting flange D.

- 1) According to ANSI B92.1a, 30° pressure angle, flat root, side fit, tolerance class 5
- 2) Thread according to DIN 13, see instruction manual for maximum tightening torques.
- 3) Continuous

PERFORMANCE DATA - DRIVE POWER AND FLOW
Size 18
Operating at

n = 1800 rpm	
n _{max} = 3300 rpm	

Q Flow	
P Power	

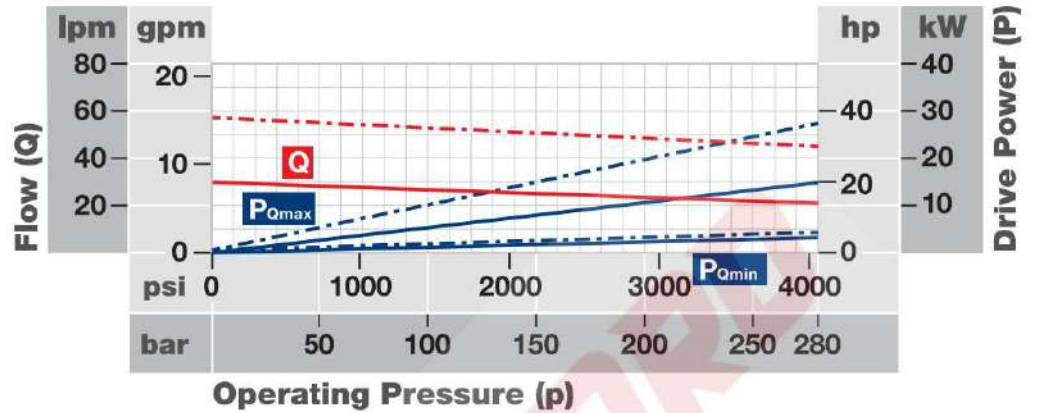
Size 28
Operating at

n = 1500 rpm	
n = 1800 rpm	
n _{max} = 3300 rpm	

Q Flow	
P Power	

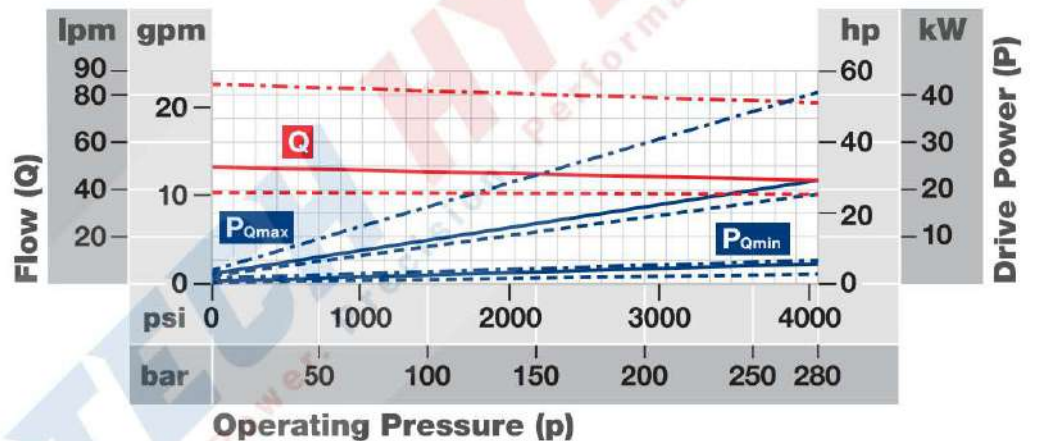
Size 45
Operating at

n = 1500 rpm	
n = 1800 rpm	
n _{max} = 2600 rpm	

Q Flow	
P Power	

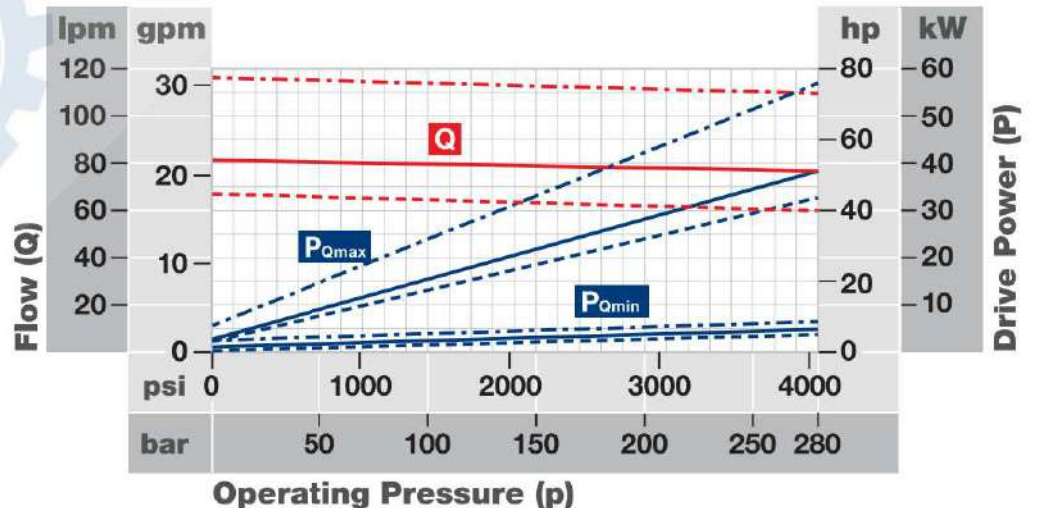

PERFORMANCE DATA - DRIVE POWER AND FLOW

Size 71

Operating at	
n = 1500 rpm	
n = 1800 rpm	
n _{max} = 2200 rpm	

Q	Flow
P	Power

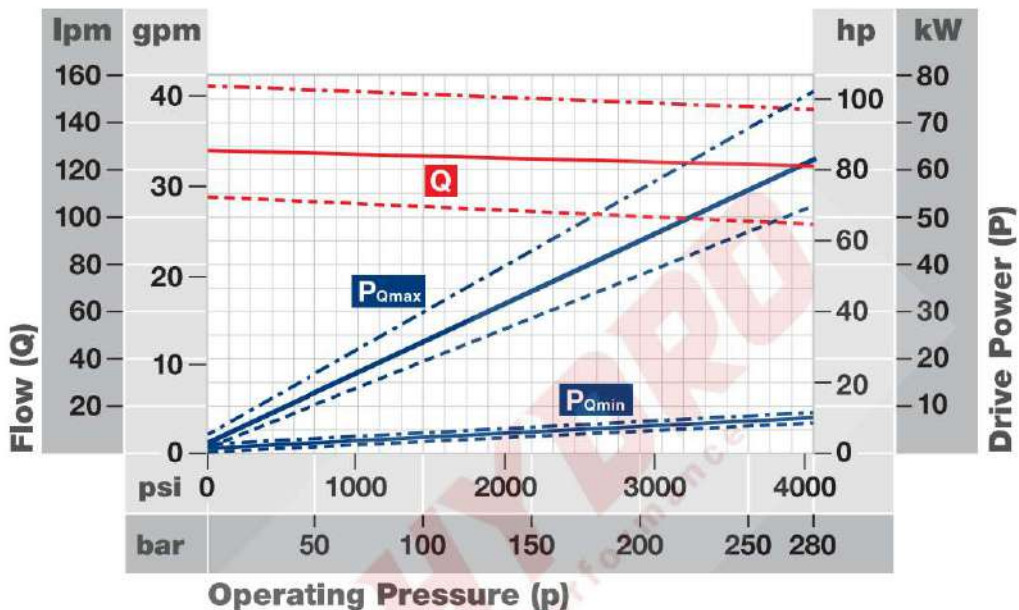

Size 100

Operating at	
n = 1500 rpm	
n = 1800 rpm	
n _{max} = 2200 rpm	

Q	Flow
P	Power

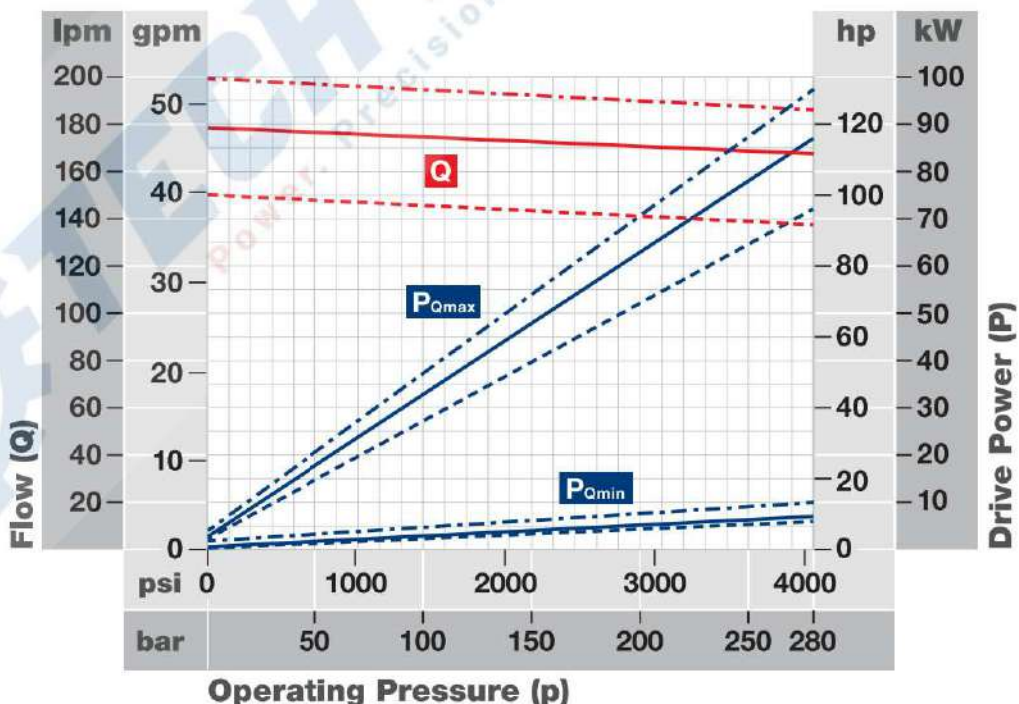

PERFORMANCE DATA - DRIVE POWER AND FLOW

Size 140

Operating at

n	= 1500 rpm	
n_{max}	= 1800 rpm	

Q	Flow
P	Power

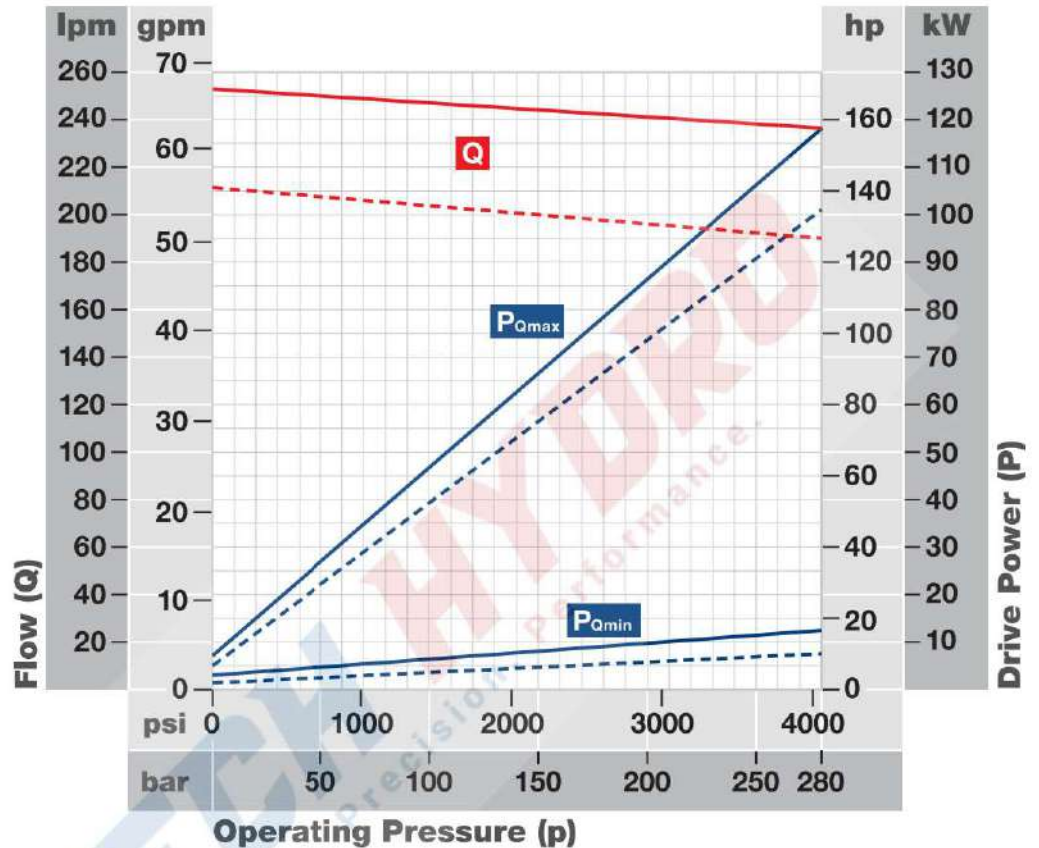

FLOW

1 gallon/minute [gpm] = 3.7854 liters/minute [lpm]
 1 liters/minute [lpm] = 0.26417 gallon/minute [gpm]

PRESSURE

1 pounds/square inch [psi] = 0.06895 [bar]
 1 [bar] = 14.5038 pounds/square inch [psi]

POWER

1 horsepower [HP] = 0.7457 kilowatt [kW]
 1 kilowatt [kW] = 1.3410 horsepower [hp]

EFFICIENCY

Total efficiency $\eta_t = \frac{Q \times p}{P_{Qmax} \times 1714(600)^*}$

Volumetric efficiency $\eta_v = \frac{Q_{act.}}{Q_{theor.}}$

Q (gpm), p (psi), P (hp) Use 1714 

Q (lpm), p (bar), P (kW) Use 600 

NOISE LEVEL

Characteristics for pump

- Measured in an sound chamber
- Distance from microphone to pump = 3.3 ft (1m)

- Measuring error: + 2 dB(A)
- Hydraulic oil to ISO VG 46 DIN 51519, $t=122^{\circ}\text{F}(50^{\circ}\text{C})$

SIZE 18

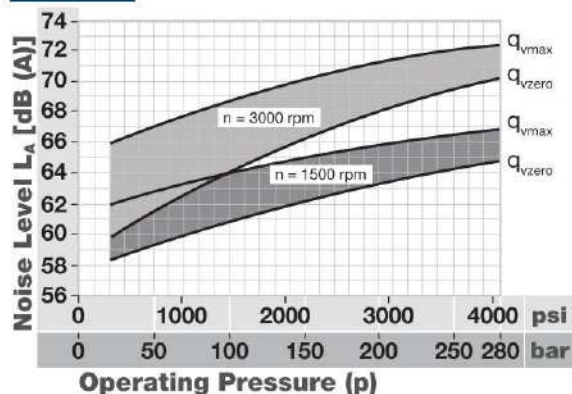

SIZE 71

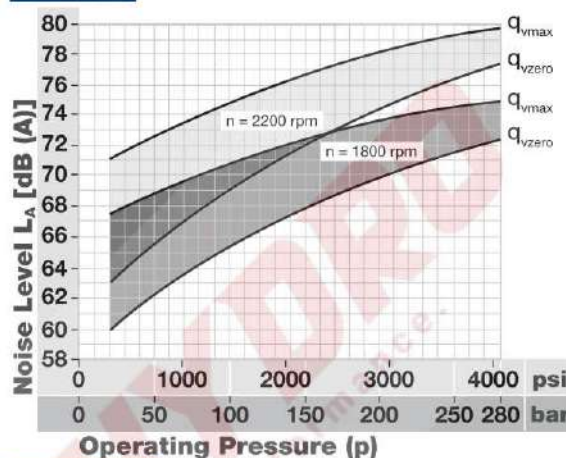

SIZE 28

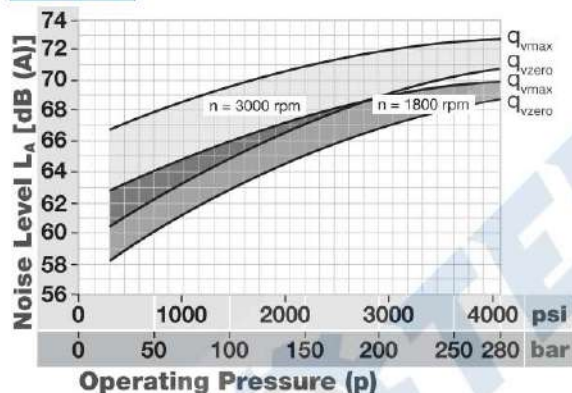

SIZE 100

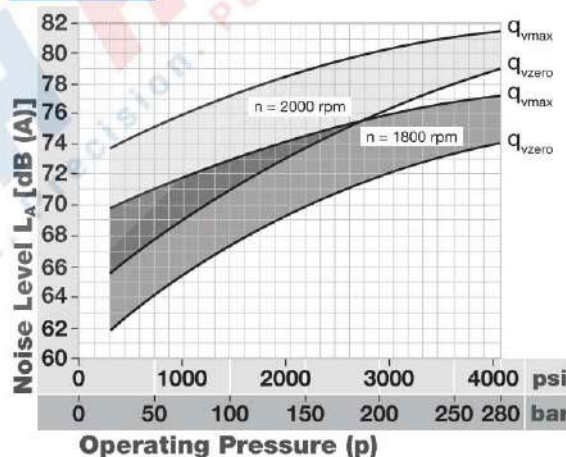

SIZE 45

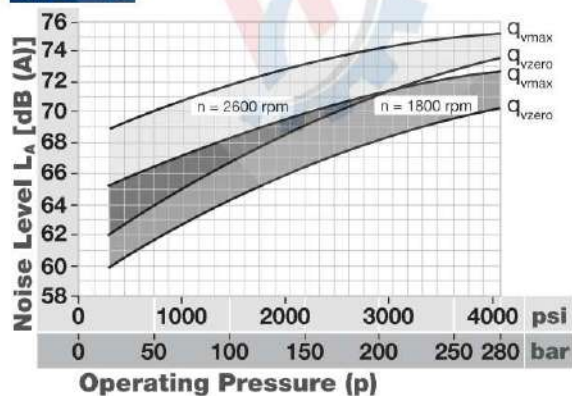

SIZE 140

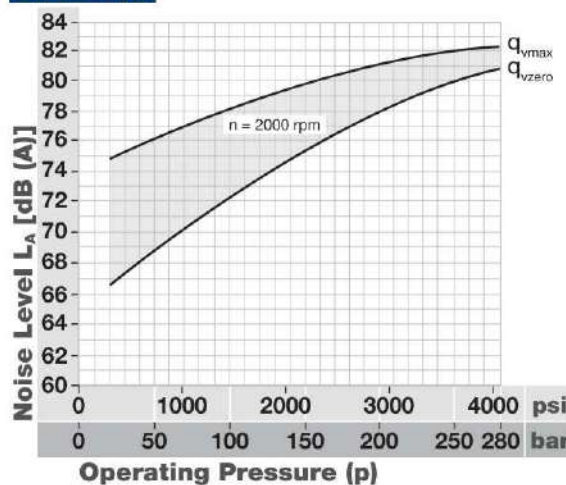

*Sound data representative of piston pumps of this design.

TECH HYDRO Variable Piston Pump TH-A10VSO series 31 - Rev. C (08/31/2023)

PUMP INSTALLATION NOTES

Optional installation position. The pump housing must be filled with fluid during commissioning and remain full when operating. In order to attain the lowest noise level, all connections (suction, pressure, case drain ports) must be linked by flexible couplings to tank. Avoid placing a check valve in the case drain line. This may, however, be permissible in individual cases, after consultation with us.

1. Vertical installation (shaft end upwards)

The following installation conditions must be taken into account:

1.1. Arrangement in tank

Before installation fill pump housing, keeping it in a horizontal position.

- If the minimum fluid level is equal to or above the pump mounting surface leave ports "L", "L1" and "S" open (see Fig.1).
- If the minimum fluid level is below the pump mounting surface pipe port "L1", and possibly "S" according to Fig. 2. Close port "L" with respect to conditions in 1.2.1.

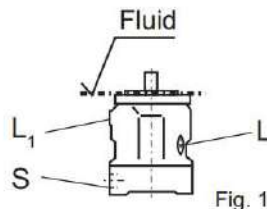

Fig. 1

1.2. Arrangement outside tank

Before installation fill pump housing, keeping it in a horizontal position. For mounting above tank see Fig. 2.

Limiting condition:

1.2.1. Minimum pump inlet pressure $p_{inlet, min} = 0,8$ bar under static and dynamic loading.

Note: Avoid mounting above tank wherever possible in order to attain a low noise level.

pressure loss, but may not be greater than $h_{max} = 800$ mm (immersion depth $h_{min} = 200$ mm).

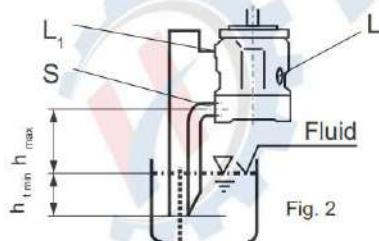

Fig. 2

The permissible suction height h is a result of the overall Total pressure loss $\Delta p_{total} = \Delta p_1 + \Delta p_2 + \Delta p_3 \leq (1 - p_{inlet, min}) = 0,2$ bar

Δp_1 : Pressure loss in pipe due to accelerating column of fluid

$$\Delta p_1 = \frac{\rho \cdot l \cdot dv}{dt} \cdot 10^{-6} \text{ (bar)} \quad \begin{aligned} \rho &= \text{density (kg/m}^3\text{)} \\ l &= \text{pipe length (m)} \\ dv/dt &= \text{change in rate of suction (m/s}^2\text{)} \end{aligned}$$

Δp_2 : Pressure loss due to static head

$$\Delta p_2 = h \cdot \rho \cdot g \cdot 10 \text{ (bar)} \quad \begin{aligned} h &= \text{height (m)} \\ \rho &= \text{density (kg/m}^3\text{)} \\ g &= \text{acc. due to gravity} = 9.81 \text{ m/s} \end{aligned}$$

Δp_3 : Line losses (elbows etc.)

Horizontal installation

The pump must be installed so that either "L" or "L1" is at the top.

2.1. Arrangement in tank

- If the minimum fluid level is above the top of the pump leave ports "L", "L1" and "S" open (see Fig. 3)
- If the minimum fluid level is equal to or below the top of the pump pipe ports "L", "L1" and possibly "S" according to Fig. 4. Conditions according to 1.2.1.

2.2. Arrangement outside tank

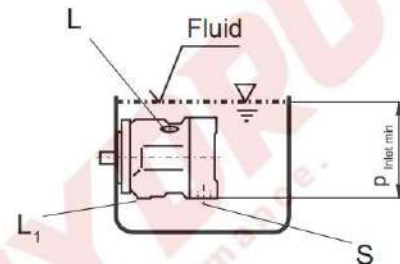

Fig. 3

Fill pump housing before commissioning.

Pipe port "S" and the higher of the two case drain ports "L" and "L1".

- For mounting above tank see Fig. 4. Conditions according to 1.2.1.
- Position below tank

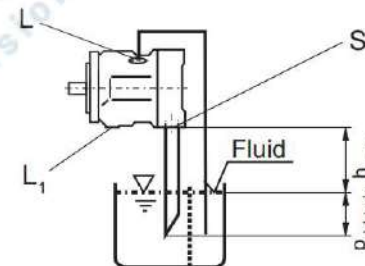

Fig. 4

Pipe ports "L" and "S" according to Fig. 5.

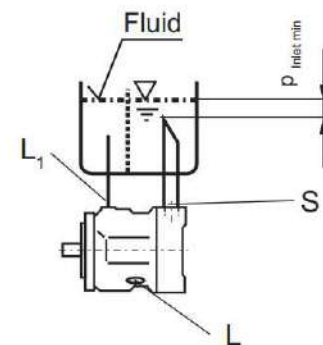

Fig. 5

FOR MORE INFORMATION PLEASE CONTACT US

SALES@TECHYDRO.COM.CN



TECHYDRO

☎ +86-15869517019

✉ SALES@techydro.com.cn

🌐 WWW.TECHYDRO.COM.CN

📞 whatsapp/Wechat: +86-15869517019

TEL: +86(0574) -87021030